



Product Catalogue
Series 300 Valves

Series 300 Valves

Series 300 Valves
Catalogue



Dorot, part of Matholding Group since 2014, is one of the world's leading manufacturers and developers of sustainable technologies and products for water control and optimization systems.

With more than 70 years of experience, the company is a worldwide pioneer in providing high quality solutions for Hydraulic Controlled Valves and Air Valves.

Customers around the globe benefit on a daily basis from our experience and wide variety of solutions and services in the following areas:

- **Waterworks Distribution Systems for civil and industrial engineering**
- **Fire Protection**
- **Industrial Applications such as Mining, Wastewater, Marine**
- **Water Treatment and Filtration**
- **Agricultural and Landscape Irrigation**
- **Water Metering and others**

Innovation and expertise are the backbones of Dorot. It drove us into developing a diverse portfolio of water and other fluids systems application, in compliance with specifications and international quality standards. Customer satisfaction and recognition is of paramount importance for Dorot. This guarantees uncompromised know-how, expertise and professionalism in planning, designing and providing the optimal hydraulic control solutions.

We invite you to join our family of business partners. Together we can provide the best control solutions for the world's most valuable natural resource: **water**



General Information	4
Overview	4
Features	4
Engineering Data	5
Technical Specifications	5
Materials	5
Basic Valve Operating Modes	6
Typical Pressure Reducing Performance Chart	10
Cavitation Data	11
Dimensions & Weights	12
Size Selection Tables	14
Headloss Charts	15
Components	16
Waterworks Control Application	17
Electronic and Remote control functions	17
EL Solenoid Control Valve	17
EL/TO Two Stage Opening Solenoid Control Valve	18
EC Electronic Control Valve	19
Pressure Regulating functions	20
PR Pressure-Reducing Valve	20
PR[D] Proportional Pressure-Reducing Valve	21
PRM Dual Set-Point Pressure-Reducing Valve	22
HyMod Flow-Modulated Pressure-Reducing Valve	23
PS[R] Pressure-Sustaining\Relief Valve	24
PS Pressure-Sustaining Valve	25
PRPS Pressure Sustaining\Reducing Valve	26
DI Pressure Differential Sustaining Valve	27
Rate of Flow Regulating functions	28
FR Flow Control Valve	28
FR/EL Flow Control Valve	29
Water Level Control functions	30
FL Modulating Float Valve	30
FLEL Electric Float Controlled Valve	31
FLDI Differential Float Valve	32
FLDI/PS Differential Float and Pressure Sustaining Valve	33
FLDI/FR(PR) Differential Float and Flow Control Valve	34
FLDI/SP Differential-Level Control Valve with Surge-Preventing closure	35
AL 3W Altitude Pilot Controlled Valve	36
CXAL 2W Altitude Pilot Controlled Valve	37
Pump Control functions	38
BC Pump Control Valve	39
BC/PS Pump Control and Pressure Sustaining Valve	39
NS Two-Stages, Cushioned Closure Check Valve	40
CV Hydraulic Non-Return Valve	41
DW Deep Well (Borehole) Pump Control Valve	42
Safety functions	43
RE Surge Anticipating Valve	43
REEL Surge Anticipating Valve	44
QR Quick Pressure-Relief Valve	45
FE Excessive Flow Shut-off Valve	46
Fire Protection Applications	47

Overview

DOROT'S 300 Series, state-of-the-art automatic control valves are designed to withstand the most demanding requirements of water system control. The experts at DOROT developed this technically-advanced valve with capabilities- far beyond any other on the market.

This Engineering Data guide will assist the reader in the selection of the optimal DOROT Series 300 valve.

Features

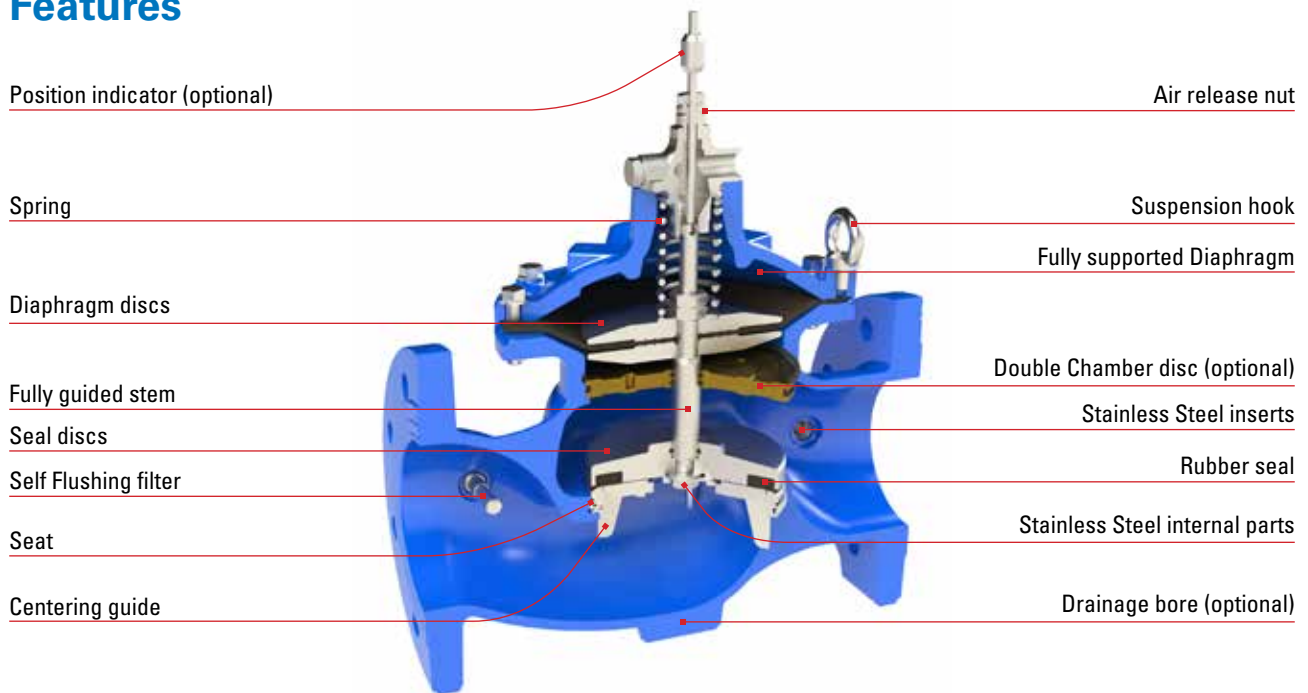

Features of the 300 Series

- The capability to regulate near zero flow, as standard on all sizes, eliminates the need for a special low flow (throttling plug) or valve, while ensuring very low head loss in "fully open" position.
- The flange (face-to-face) dimensions suit ISO Standards.
- The valve has an internal floating shaft, allowing for frictionless operation. The unique design of the shaft provides for easy field maintenance.
- The valve has a resilient seal disc, guided by a frictionless centering device.
- The valve's body is made of Ductile Iron, withstanding both high hydraulic and mechanical stresses.
- The standard single - chamber valve provides smooth operation in sensitive regulation conditions. When required, conversion from a single to a double chambered valve is easily accomplished through the insertion of Dorot's innovative separation disc, without the need to remove the valve from the pipeline during the conversion.
- The valve is supplied with a replaceable Stainless Steel seat, which maintains excellent durability against erosion and ensures a drip-tight seal.
- During valve closure the rate slows, preventing potential damage from water hammer or surges.
- The 300 Series includes an optional valve position indicator, attached by a floating connection (ball & socket), resulting in smooth movement, with no wear or tear on the indicator seal.

Technical Specifications

Parameter	Standard	Optional
Connections	<ul style="list-style-type: none"> Flanged ISO 7005 or ANSI B16 Threaded BSP or NPT 	<ul style="list-style-type: none"> Flanged AS10, JIS B22, ABNT and others
Pressure range	<ul style="list-style-type: none"> Model 30: 0.5 – 16 bar 7 – 250 psi Models 31, 32: 0.5 – 25 bar 7 – 360 psi 	<ul style="list-style-type: none"> 0 min. press. with N.O spring assisted opening. 0.2 bar / 3 psi min. pressure without a spring <p>Note: both options require usage of external higher closing pressure</p>
Max. Water Temperature	<ul style="list-style-type: none"> 80°C / 180°F 	<ul style="list-style-type: none"> 95°C / 200°F

Materials

Part	Standard	Optional
Body & Cover	Ductile Iron GGG50 (ASTM A-536)	Cast Steel A-216 WCB Cast Bronze or Marine Bronze Cast SST CF8M (316) Ni Aluminum Bronze Others
Main Valve Internals	SST, Bronze and Coated Steel	SST 316, HASTELLOY, SMO, DUPLEX
Spring	SST 302	SST 316, INCONNEL
Diaphragm	Nylon fabric reinforced EPDM (WRAS and NSF approved)	NBR, Viton
Seals	EPDM	NBR, Viton
Coating	Polyester RAL 5010	FBE RAL 5010 Polyester RAL3000 (fire red) UV protected FBE RAL3000 Rilsan (Nylon) Halar
Control Trim: Fittings and control devices	Brass	SST 304 SST 316, Duplex
Control Trim: Tubes	Reinforced, heavy-duty Nylon, Polypropylene	Copper SST 316, Duplex

Note: The Dorot S-300 valves in all sizes, meet the USA amendment for reducing lead in drinking water marked as S.3874 dated 01.05.2010.

Basic Valve Operating Modes

On-Off Mode

Standard (Single Chamber) Valve

Closed Mode: The control pressure (taken from the pipeline) is applied by the control device to the control chamber (top of the diaphragm). The pipeline pressure pushes the seal to open, and the control chamber pressure forces the diaphragm to close. Since the diaphragm area is larger than the seal area, it has greater hydraulic force so the valve remains in the closed position.

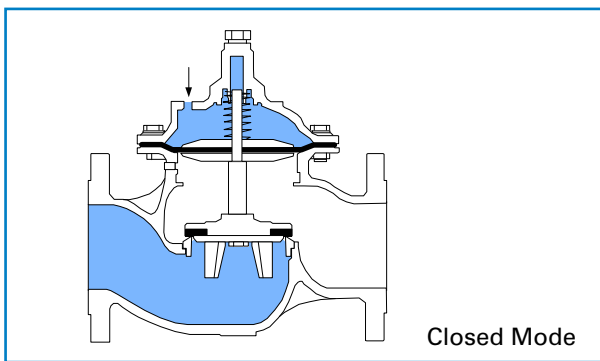

Open Mode: The control device relieves the pressure from the control chamber. The pipeline pressure forces the seal to the "open" position so that the fluid can pass through the valve. While the valve is open, outlet pressure is applied to the lower side of the diaphragm, assisting the opening.

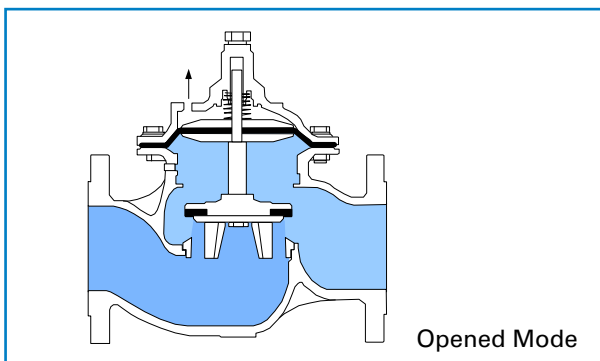

Double Chamber Valve (Version D)

The double chamber version is created by inserting a separation disc between the diaphragm and the seal. This assembly creates a second control chamber below the diaphragm, permitting for the activation of the valve in low-pressure systems and enabling the activation faster valve response. The response to varying conditions is quick, since closure downward movement is not resisted by pressure below the diaphragm.

Closed Mode: The control pressure (taken from the pipeline or from supplementary pressure source) is applied to the top of the external diaphragm. The bottom control chamber drains. The pipeline pressure pushes the seal to open, but since the diaphragm area is larger than the seal area it creates greater hydraulic force and which forces the valve to close thus the valve closes. At this stage, the bottom chamber should be drained.

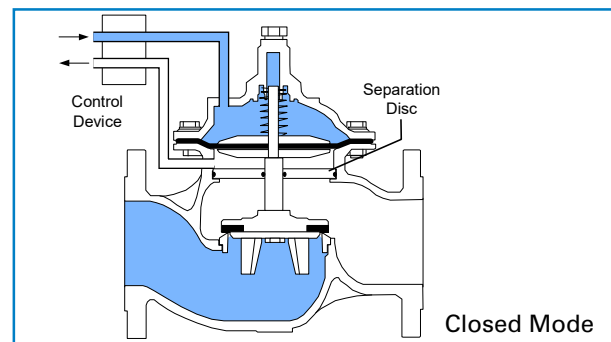

Open Mode: The control device releases the pressure from the top control chamber. The seal assembly is forced to the "open" position by the pipeline pressure, allowing flow through the valve.

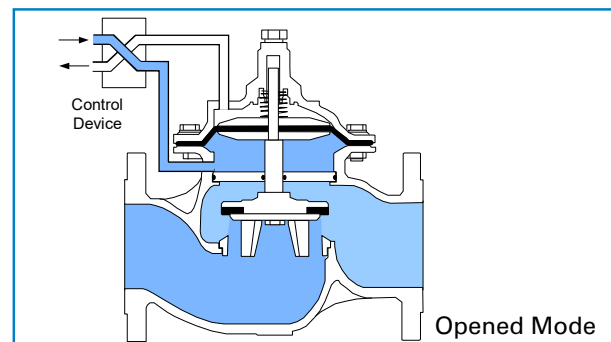

Modulating Mode

General

Positioning the seal a short distance (less than 1/4 of the seat diameter) from the seat, creates friction and turbulence, causing energy loss in the fluid passing through the valve. The results are:

- Reduction of pressure and flow rate.
- Increase of inlet pressure.

The position of the seal assembly is dictated by the volume of control fluid in the top control chamber, which is determined by the control device. The control device is operated by hand (manual control), by electric current (solenoid valve), or by hydraulic pressure (pilot valves, hydraulic relays). All can be used in standard (single chamber) valves as well as in double chamber valves.

Modulating mode in standard (single chamber) valves

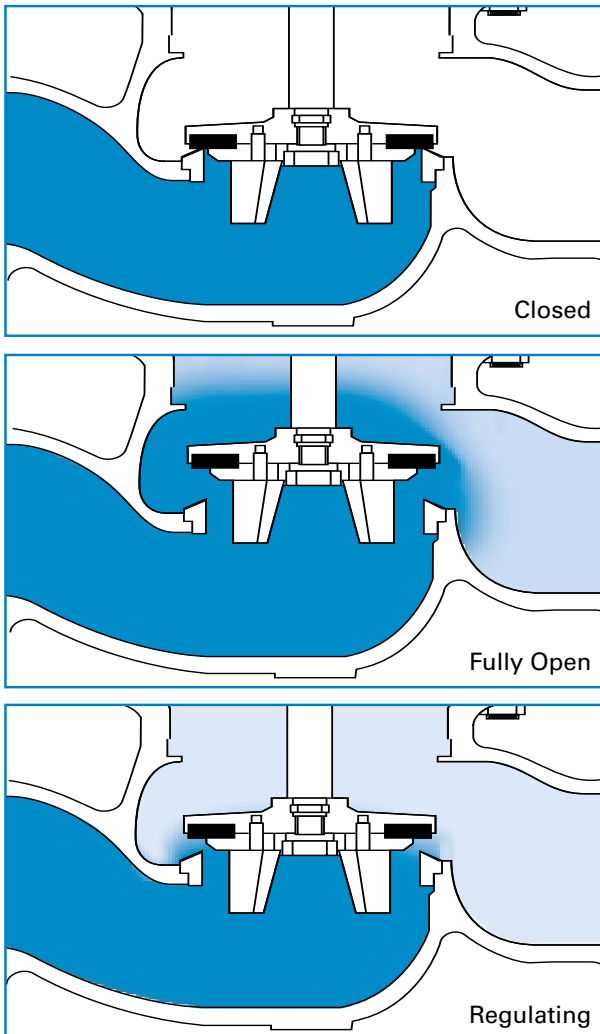

Regulation at high pressures difference

The S-300 has exceptional resistance to damages, caused by cavitation conditions. This feature was certified by extensive tests, carried by an independent laboratories in US and Europe. The operation limits, as found in these tests, can be calculated for any specific location- using a simple computer program (supplied on request). For operation conditions that exceed the safe limit- a special Cavitation-Free valve can be supplied. This version, marked by the suffix "F" (example 30F-3 is a cavitation-free, 80mm / 3" valve), can operate at any pressure differential without being ruined by it. The internal structure includes a Stainless Steel, perforated cylinder, that is connected below the standard seal disc and moving freely inside the seat. The valve is assembled to generate "over the seat" flow, so the water stream enters the cylinder from its external side and emerges through the internal side. The energy is dissipated by the high-velocity, turbulent flow through the exposed holes above the seat (due to varying trim position). The pressure recovery, that is the cause of cavitation damage, happens now inside the cylinder and not adjacent to the body wall. As the SST material is highly- resistant to cavitation- it is not damaged.

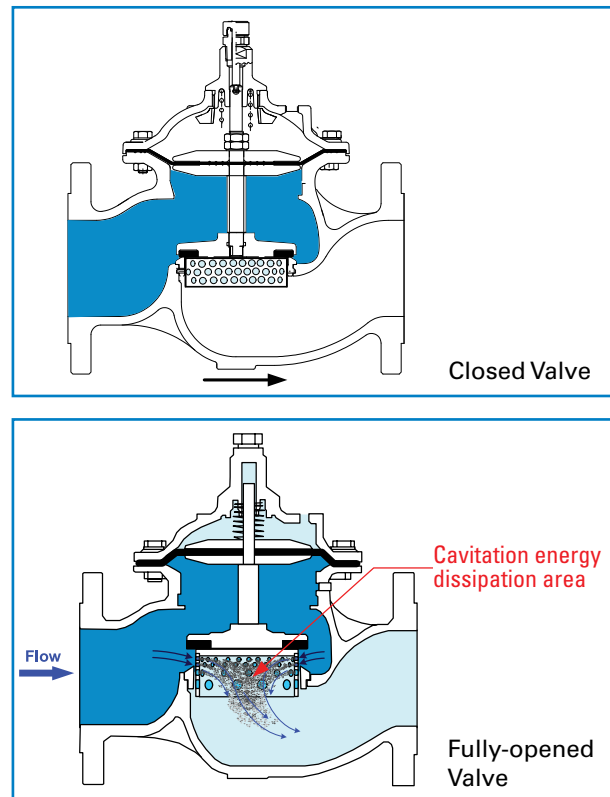

2-Way Control Device

The 2-way control device is assembled on a control circuit, connecting upstream to downstream through the control chamber.

There are two restrictors assembled in this circuit:

(a) A nozzle or a needle valve, at a fixed opening.

(b) A modulating device (pilot), whose passage may vary from complete closure ($b=0$) to a fully open size (when $b>a$).

The volume of the control media in the chamber is determined by the relative passages (a) and (b), or, in fact, by the opening of (b), as (a) is fixed.

Closed Mode: Pilot (b) senses a downstream pressure higher than the set-point and closes passage (b). Through passage (a) the upstream water flows directly into the upper part of the control chamber, forcing the diaphragm to close the valve.

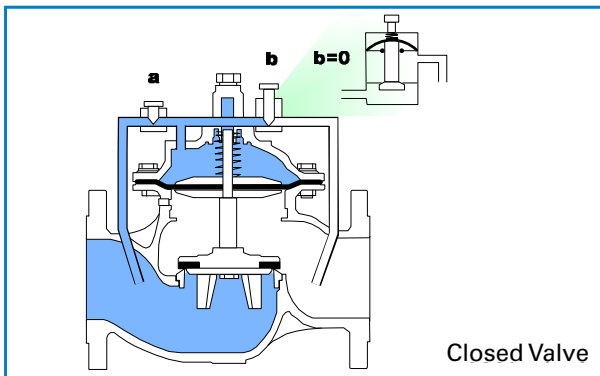

Open Mode: Pilot (b) senses a downstream pressure lower than the set-point, and fully opens passage (b), larger than (a). All the water from the upstream flows through (a) and (b), directly to the downstream, allowing water from the upper part of the control chamber to partially drain until the pressure in the chamber equals the downstream pressure. Pressure in the upper part of the control chamber is decreased and the upstream water pressure forces the seal disc to rise (opening the valve).

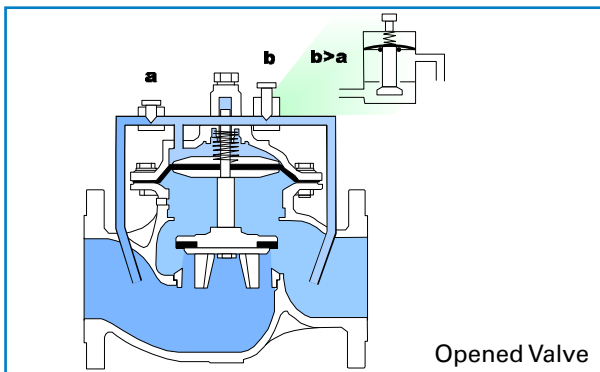

Regulating Mode: The pilot is set to the required downstream pressure. The pilot senses when the downstream pressure reaches the required value causing passage (b) to equal passage (a) $b=a$. Now, water that flows through the control loop passes from (a) through (b) and into the downstream. The control media in the upper part of the control chamber is now steady, keeping the diaphragm and seal in a fixed position. Any change in the downstream pressure will change the $b=a$ balance. This change adds or drains water from the control chamber, thus opening or closing the main valve until it reaches the balanced regulating position $b=a$ once again.

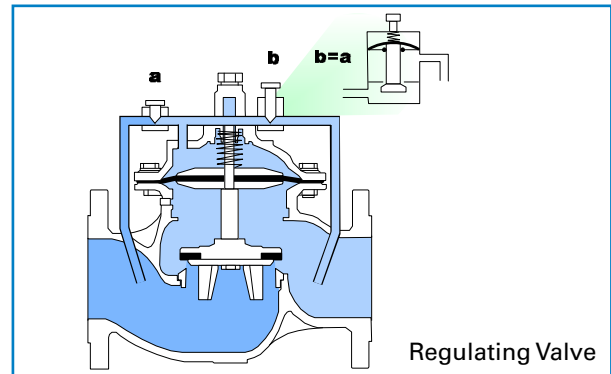

The 2-way control device provides sensitive, accurate, and constant modulating, control of the main valve. The main valve does not fully open, as the control device prevents total draining of the control chamber. The 2-way control device is standard in most pressure regulating valves.

3-Way Control Device

The 3-way control device is a small selector valve which:

1. Permits passage of the control media into the main valve control chamber (initiating the "closing" procedure), or
2. Permits drainage of the control media from the control chamber to the atmosphere (initiating the "opening" procedure).

Some of the 3-way control devices have a third mode as well, which prevents inflow or outflow from the control chamber, so that the main valve remains fixed when the device is in this mode.

The 3-way mode is used in on-off valves or when the regulating valve is fully open, in order to obtain specific operating conditions. Once in position, there is no water flow through the control chamber.

The 3-way control circuit may open the main valve entirely, creating minimum head loss.

The 3-way control device must be used when external media (not pipeline water) is used to control the valve, or when the control media is dirty or abrasive.

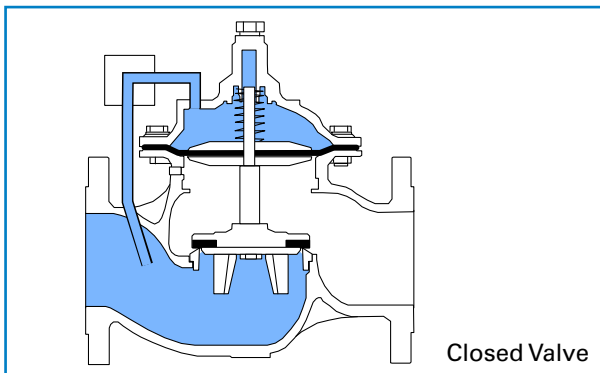

Closed Valve

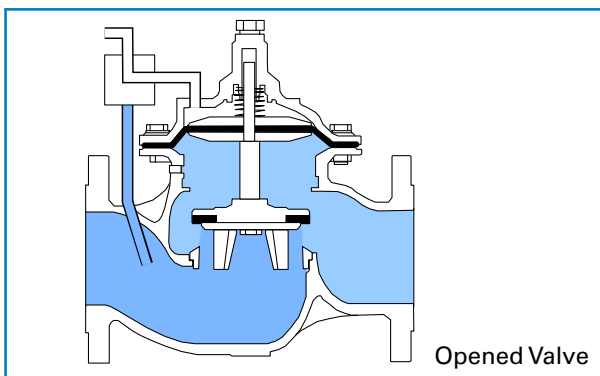

Opened Valve

Proportional Pressure Reducer

The proportional pressure reducer is a valve that has a control chamber permanently connected to the downstream.

This valve must be a double chamber [D] type.

The balance of hydraulic forces created between the high pressure on the small seal area, and the lower downstream pressure on the larger diaphragm area, causes a fixed ratio of inlet/outlet pressure of approximately 3:1.

No other control device is needed.

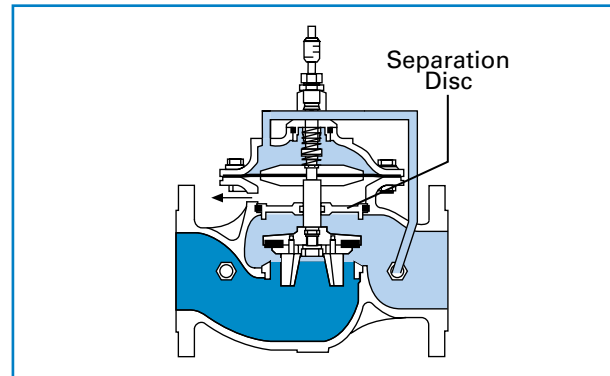

Separation Disc

Typical Pressure Reducing Performance Chart

100 mm / 4" Dorot 300 Series Pressure Reducing Valve

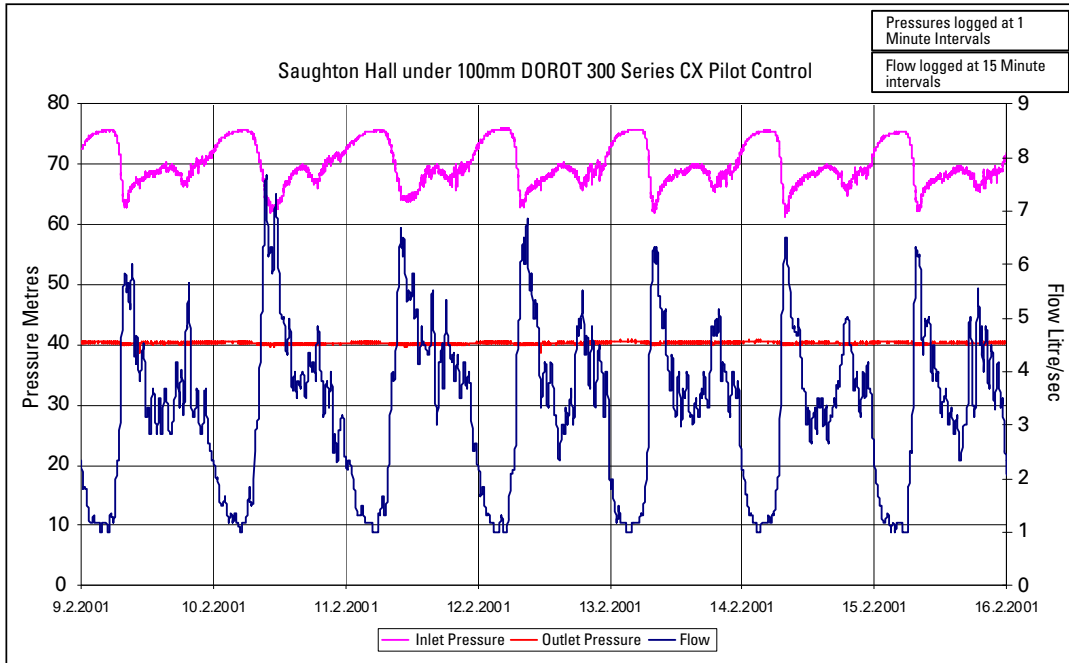

Comparison of different seal structures

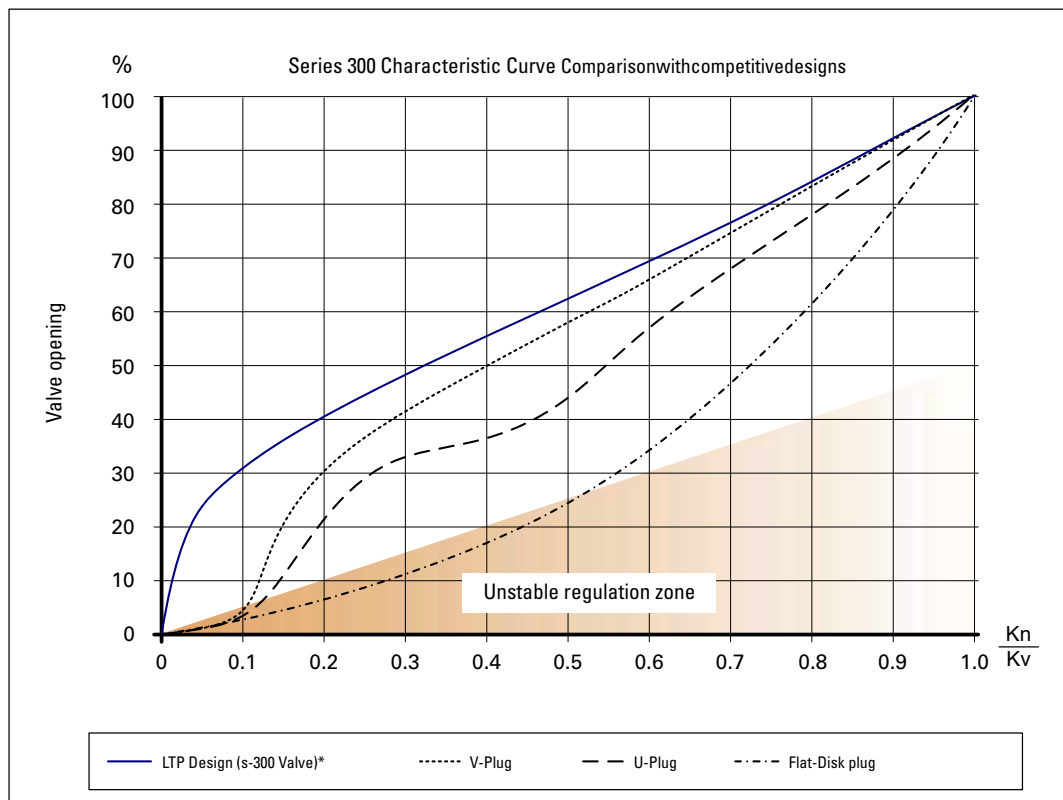

* Independent laboratory report data source

Cavitation Data

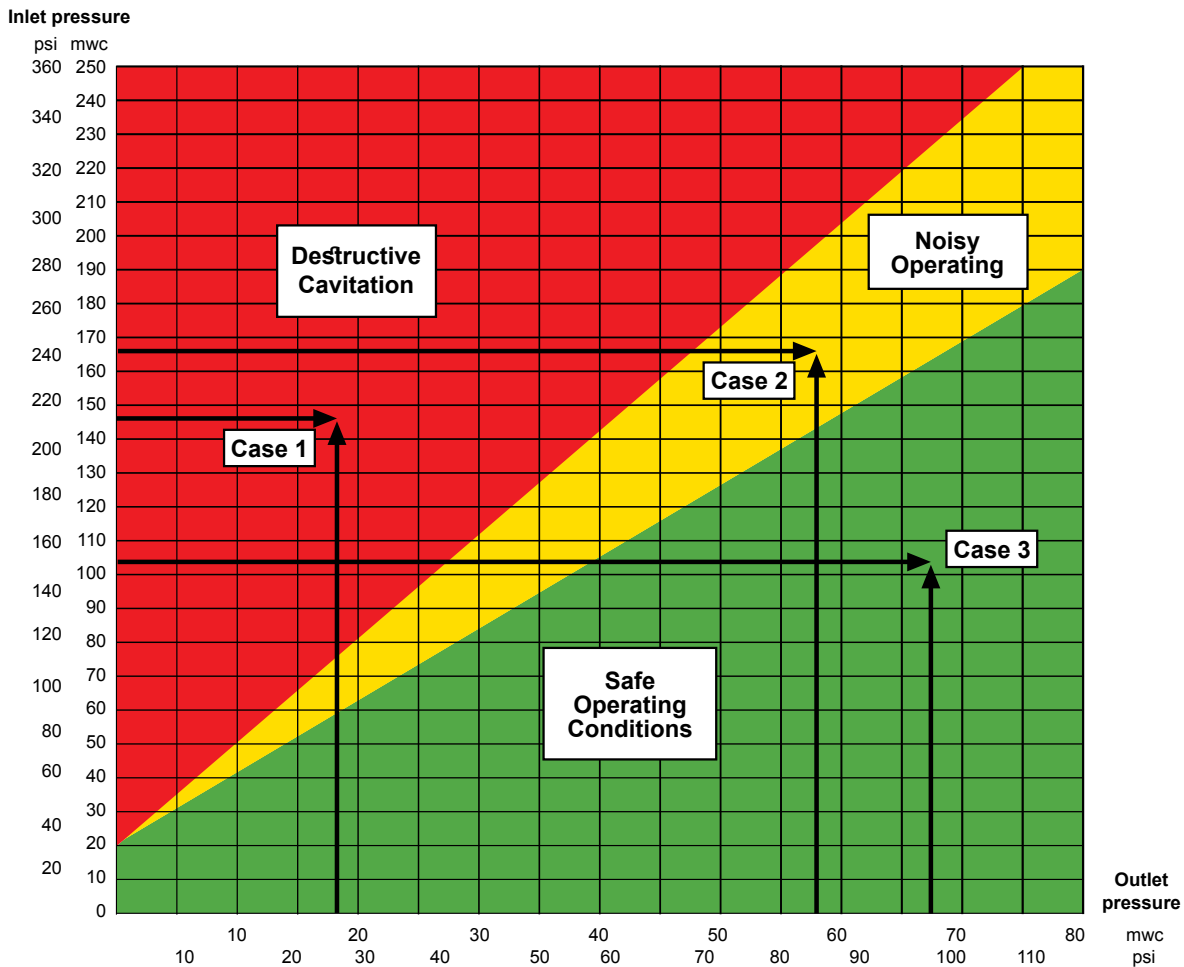

Cavitation Chart

Limits of operating conditions

The chart above sets the safe limits for valves that are supposed to operate at a considerable pressure differential.

Such conditions generate noise and possible cavitation damages to the valve body.

How to use the chart:

- Determine the maximal dynamic pressure that may be applied in the inlet of the valve.
- Draw an horizontal line from the pressure scale at the left side of the chart
- Find the requested outlet pressure in the pressure scale at the bottom of the chart.
- Draw an upward line at this point.
- The intersection of the two lines defines the cavitation characteristics of the valve operation.
 - In the case that it falls in the RED zone (case I)- the valve may be damaged in a fairly short time.
 - In the case that it falls in the YELLOW zone (case II)- the valve may generate a noise that exceeds 80db.
 - In the case that the intersection is within the GREEN zone (case III)- the valve will perform safely and quietly

General remark: The cavitation and noise data are based on tests done by the Utah State University, US, and Delft Hydraulic Laboratories, Holland.

Dimensions & Weights

Models 30 (16 bar rated valves) / 31 (25 bar rated valves)

Globe Flanged Type

Valve Size	40 (1½")		50 (2")		65 (2½")		80 (3")		100 (4")		150 (6")		200 (8")		250 (10")	
	mm	inch	mm	inch	mm	inch	mm	inch	mm	inch	mm	inch	mm	inch	mm	inch
L	230	9 ¹ / ₁₆	230	9 ¹ / ₁₆	290	11 ³ / ₈	310	12 ³ / ₁₆	350	13 ³ / ₄	480	18 ⁷ / ₈	600	23 ⁵ / ₈	730	28 ³ / ₄
L (ANSI#300)	230	9 ¹ / ₁₆	235	2 ³ / ₁₆	292	12 ¹ / ₂	345	13 ¹ / ₂	400	15 ¹ / ₁₆	525	20 ⁵ / ₈	605	23 ¹³ / ₁₆	790	31 ¹ / ₈
H	185	7 ⁵ / ₁₆	185	7 ⁵ / ₁₆	185	7 ⁵ / ₁₆	230	9 ¹ / ₁₆	240	9 ¹ / ₁₆	330	13	390	15 ⁵ / ₈	520	20 ¹ / ₂
h**	140	5 ¹ / ₂	140	5 ¹ / ₂	140	5 ¹ / ₂	170	6 ¹¹ / ₁₆	180	7	230	9	300	11 ¹³ / ₁₆	390	15 ¹ / ₄
W	153	6	170	6 ¹¹ / ₁₆	185	7 ³ / ₁₆	200	7 ⁷ / ₈	235	9 ¹ / ₄	330	13	415	16 ⁵ / ₁₆	525	20 ¹¹ / ₁₆
R	82.5	3 ¹ / ₄	82.5	3 ¹ / ₄	92.5	3 ⁵ / ₈	100	3 ¹⁵ / ₁₆	110	4 ⁵ / ₁₆	142.5	5 ⁵ / ₈	172.5	6 ³ / ₄	205	8 ¹ / ₁₆
Weight Kg/lbs*	12 / 26		12 / 26		13 / 29		22 / 49		37 / 82		80 / 176		157 / 346		245 / 540	
Vol. control chamber lit/gal	0.1 / 0.02		0.1 / 0.02		0.1 / 0.02		0.3 / 0.08		0.7 / 0.2		1.5 / 0.4		4.3 / 1.1		9.7 / 2.6	

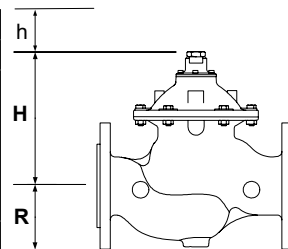

Valve Size	300 (12")		350 (14")		400 (16")		450 (18")		500 (20")		600 (24")		700 (28")		800 (32")	
	mm	inch	mm	inch	mm	inch	mm	inch	mm	inch	mm	inch	mm	inch	mm	inch
L	850	33 ³ / ₁₆	980	38 ⁹ / ₁₆	1100	43 ³ / ₁₆	1200	47 ¹ / ₄	1250	49 ³ / ₁₆	1450	57 ¹ / ₁₆	1650	64 ¹⁵ / ₁₆	1850	72 ⁷ / ₈
L (ANSI#300)	910	35 ¹³ / ₁₆	980	38 ⁹ / ₁₆	1100	43 ³ / ₁₆	1200	47 ¹ / ₄	1250	49 ³ / ₁₆	1450	57 ¹ / ₁₆	1650	64 ¹⁵ / ₁₆	1850	72 ⁷ / ₈
H	635	25	635	25	855	33 ⁵ / ₈	855	33 ⁵ / ₈	855	33 ⁵ / ₈	1574	61 ¹⁵ / ₁₆	1675	65 ¹⁵ / ₁₆	1675	65 ¹⁵ / ₁₆
h**	450	17 ¹¹ / ₁₆	450	17 ¹¹ / ₁₆	590	23 ¹ / ₄	600	23 ³ / ₈	600	23 ³ / ₈	740	29 ¹ / ₈	860	33 ³ / ₈	860	33 ³ / ₈
W	610	24	610	24	850	33 ³ / ₁₆	850	33 ³ / ₁₆	850	33 ³ / ₁₆	1100	43 ⁵ / ₁₆	1100	43 ⁵ / ₁₆	1090	42 ¹⁵ / ₁₆
R	230	9	272	10 ¹¹ / ₁₆	290	11 ¹ / ₁₆	310	12 ³ / ₁₆	357.5	14 ¹ / ₁₆	490	19 ⁵ / ₁₆	498	19 ⁵ / ₈	603	23 ³ / ₄
Weight Kg/lbs*	405 / 893		510 / 1124		822 / 1812		945 / 2083		980 / 2160		1950 / 4299		2070 / 4560		2600 / 5730	
Vol. control chamber lit/gal	18.6 / 4.9		18.6 / 4.9		50 / 13.2		50 / 13.2		50 / 13.2		84 / 22.2		84 / 22.2		84 / 22.2	

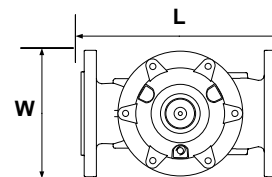

Angle Type

Valve Size	50 (2")		80 (3")		100 (4")		150 (6")		200 (8")		250 (10")	
	mm	inch	mm	inch	mm	inch	mm	inch	mm	inch	mm	inch
AL	208	8 ³ / ₁₆	250	9 ³ / ₁₆	295	11 ¹ / ₁₆	405	16	505	19 ¹ / ₈	585	23
AH	240	9 ¹ / ₁₆	415	16 ⁵ / ₁₆	445	17 ¹ / ₂	570	22 ⁷ / ₁₆	635	25	832	32 ³ / ₄
AW	170	6 ¹ / ₁₆	200	7 ⁷ / ₈	235	9 ¹ / ₄	330	13	415	16 ⁵ / ₁₆	495	19 ¹ / ₂
AR	107	4 ³ / ₁₆	138	5 ¹ / ₁₆	147	5 ¹³ / ₁₆	180	7 ¹ / ₁₆	302	11 ⁷ / ₈	338	13 ³ / ₁₆
AB	125	4 ¹⁵ / ₁₆	150	5 ⁷ / ₈	173	6 ¹³ / ₁₆	240	9 ¹ / ₁₆	300	11 ¹³ / ₁₆	338	13 ³ / ₁₆
Weight kg/lbs*	12 / 26		20 / 44		37 / 81		76 / 167		150 / 330		234 / 550	

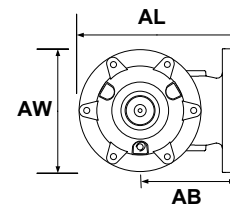
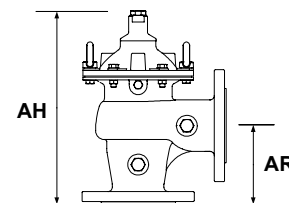

Globe Threaded Type

Valve Size	40 (1½") TH		50 (2") TH	
	mm	inch	mm	inch
TL	215	8 ⁷ / ₁₆	215	8 ⁷ / ₁₆
TH	185	7 ⁵ / ₁₆	185	7 ⁵ / ₁₆
h	140	5 ¹ / ₂	140	5 ¹ / ₂
TW	129	5	129	5
TR	62	2 ³ / ₈	62	2 ³ / ₈
Weight kg/lbs*	7 / 15		7 / 15	

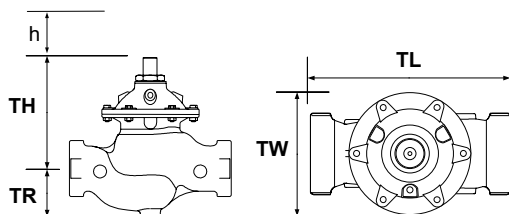

Grooved Type

Valve Size	50 (2")		80 (3")		100 (4")		150 (6")	
	mm	inch	mm	inch	mm	inch	mm	inch
VL	215	8 ¹ / ₂	351	13 ¹³ / ₁₆	376	14 ¹³ / ₁₆	521	20 ¹ / ₂
VH	173	6 ¹³ / ₁₆	228	9	240	9 ¹ / ₁₆	330	13
h	140	5 ¹ / ₂	170	6 ¹ / ₁₆	180	7 ¹ / ₁₆	230	9 ¹ / ₁₆
VW	128	5	197	7 ³ / ₄	236	9 ⁹ / ₁₆	331	13 ¹ / ₁₆
VR	78	3	106	4 ¹ / ₁₆	118	4 ⁵ / ₈	147.5	5 ¹³ / ₁₆
Weight kg/lbs*	6.5 / 14.5		15.1 / 33.25		26.5 / 58.5		58.25 / 128.5	

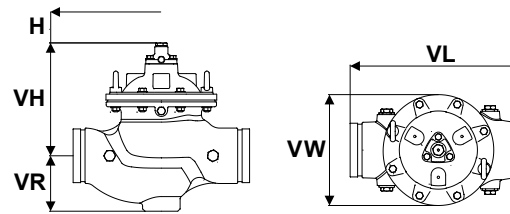

* Approximate shipping Weight (PN 25)
 ** h = Minimal required maintenance space

- End Connections (for PN16 or PN25)
- ISO 2084, 2441, 5752 ANSI B16, AS2129, JIS B22

Dimensions & Weights

Model 32 (25 bar rated valves)

Globe Flanged Type

Valve Size	80 (3")		100 (4")		150 (6")		200 (8")		250 (10")	
	mm	inch	mm	inch	mm	inch	mm	inch	mm	inch
L	310	12 ³ / ₁₆	350	13 ³ / ₄	480	18 ⁷ / ₈	600	23 ⁵ / ₈	730	28 ³ / ₄
H	185	7 ¹ / ₄	232	9 ³ / ₁₆	250	10	334	13 ¹ / ₈	395	15 ¹ / ₂
h**	107	4 ¹ / ₄	156	6 ¹ / ₈	170	6 ³ / ₄	220	8 ¹¹ / ₁₆	275	10 ¹³ / ₁₆
W	200	7 ⁷ / ₈	235	9 ¹ / ₄	300	11 ³ / ₄	360	14 ³ / ₁₆	425	16 ³ / ₄
R	100	3 ¹⁵ / ₁₆	120	4 ¹¹ / ₁₆	150	5 ⁷ / ₈	182	6 ³ / ₁₆	215	8 ⁷ / ₁₆
Weight Kg/lbs*	15 / 33		27 / 60		51 / 112		92 / 202		171 / 377	
Vol. control chamber lit/gal	0.1 / 0.02		0.3 / 0.08		0.7 / 0.2		1.5 / 0.37		4.3 / 1.1	

Valve Size	300 (12")		350 (14")		400 (16")		450 (18")		500 (20")		600 (24")	
	mm	inch	mm	inch	mm	inch	mm	inch	mm	inch	mm	inch
L	850	33 ³ / ₁₆	980	38 ⁹ / ₁₆	1100	43 ⁵ / ₁₆	1200	47 ¹ / ₄	1250	49 ³ / ₁₆	1259	49 ⁹ / ₁₆
H	545	21 ¹ / ₂	635	25	635	25	855	33 ⁵ / ₈	855	33 ³ / ₈	1311	51 ⁵ / ₈
h**	400	15 ³ / ₄	480	18 ⁷ / ₈	480	18 ⁷ / ₈	600	23 ⁵ / ₈	600	23 ⁵ / ₈	245	9 ⁵ / ₈
W	489	19 ¹ / ₄	610	24	628	24 ³ / ₄	850	33 ³ / ₁₆	850	33 ³ / ₁₆	881	34 ¹¹ / ₁₆
R	245	9 ³ / ₈	260	10 ³ / ₁₆	314	12 ² / ₈	310	12 ² / ₁₆	357.5	14 ¹ / ₁₆	459	18 ¹ / ₁₆
Weight Kg/lbs*	330 / 726		510 / 1124		544 / 1197		945 / 2083		980 / 2160		1030 / 2266	
Vol. control chamber lit/gal	9.7 / 2.6		18.6 / 4.9		18.6 / 4.9		50 / 13.2		50 / 13.2		50 / 13.2	

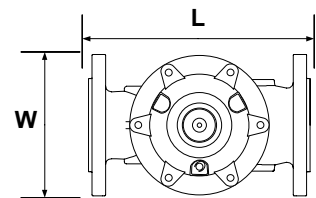
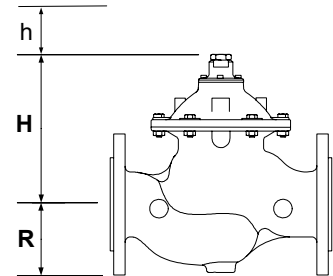

Grooved Type

Valve Size	80 (3")		100 (4")		150 (6")	
	mm	inch	mm	inch	mm	inch
VL	310	12 ³ / ₁₆	348	13 ¹¹ / ₁₆	480	20 ¹ / ₂
VH	173	6 ¹³ / ₁₆	228	9	330	13
h**	107	4 ³ / ₁₆	156	6 ¹ / ₈	230	9 ¹ / ₁₆
VW	128	5 ¹ / ₁₆	197	7 ³ / ₄	331	13 ³ / ₁₆
VR	78	3 ¹ / ₁₆	105	4 ¹ / ₈	122	5 ¹³ / ₁₆
Weight kg/lbs*	6.5 / 14.3		15 / 33		48 / 105	

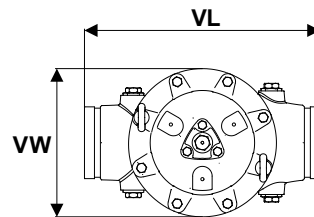
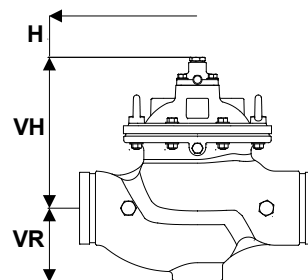

* Approximate shipping Weight (PN 25)
 ** h = Minimal required maintenance space

- End Connections (for PN16 or PN25)
- ISO 2084, 2441, 5752 ANSI B16, AS2129, JIS B22.

Size Selection Tables

Models 30 (16 bar rated valves) / 31 (25 bar rated valves)

Valve Size	40 (1½")	50 (2")	65 (2½")	80 (3")	100 (4")	150 (6")	200 (8")	250 (10")	300 (12")	350 (14")	400 (16")	450 (18")	500 (20")	600 (24")	700 (28")	800 (32")	
Max. recommended flow rate for continuous operation (m³/h)	25	40	40	100	160	350	620	970	1400	1900	2500	3100	3600	5600	7600	8135	
Max. recommended flow rate for continuous operation (Gpm)	110	180	180	440	700	1600	2800	4300	6200	8400	11000	13660	15800	24700	33500	35840	
Min. recommended flow rate	<1m³/h (<5 gpm)																
Globe Type																	
Flow Rate Factor:	Kv (Metric)	43	43	43	115	167	407	676	1160	1600	1600	3000	3150	3300	6500	6500	6500
	Cv (US)	50	50	50	133	195	475	790	1360	1900	1900	3500	3700	3860	7600	7600	7600
Head Loss Factor K (dimensionless)	2.2	5.4	15.4	4.8	5.6	4.8	5.5	4.5	5	9	3.8	6	5.9	4.8	8.9	15.2	
Angle Type																	
Flow Rate Factor:	Kv (Metric)	60	60		140	190	460	770	1310								
	Cv (US)	70	70		164	222	537	900	1533								
Head Loss Factor K (dimensionless)	1.3	2.8		3.3	4.3	4.3	4.2	3.6									

For head Loss of fully open valves use the following equations:
 $H \text{ (Bar)} = \left(\frac{Q \text{ [m}^3\text{/h]}}{Kv}\right)^2$ | $H \text{ (Psi)} = \left(\frac{Q \text{ [gpm]}}{Cv}\right)^2$ | $H = K \frac{V^2}{2g}$

Model 32 (25 bar rated valves)

Valve Size	80 (3")	100 (4")	150 (6")	200 (8")	250 (10")	300 (12")	350 (14")	400 (16")	450 (18")	500 (20")	600 (24")	
Max. recommended flow rate for continuous operation (m³/h)	60	145	225	510	970	1400	1900	2030	3100	3600	3600	
Max. recommended flow rate for continuous operation (Gpm)	265	640	990	2250	3990	6200	8400	8940	13660	15860	15860	
Min. recommended flow rate	<1 m³/h (<5 GPM)											
Flow rate factor:	Kv	43	115	165	345	663	1160	1600	1600	3000	3000	3000
	Cv	50	133	192	400	770	1360	1900	1900	3500	3500	3500

Headloss Charts

Models 30/31 (Globe Pattern) Pressure Loss Chart

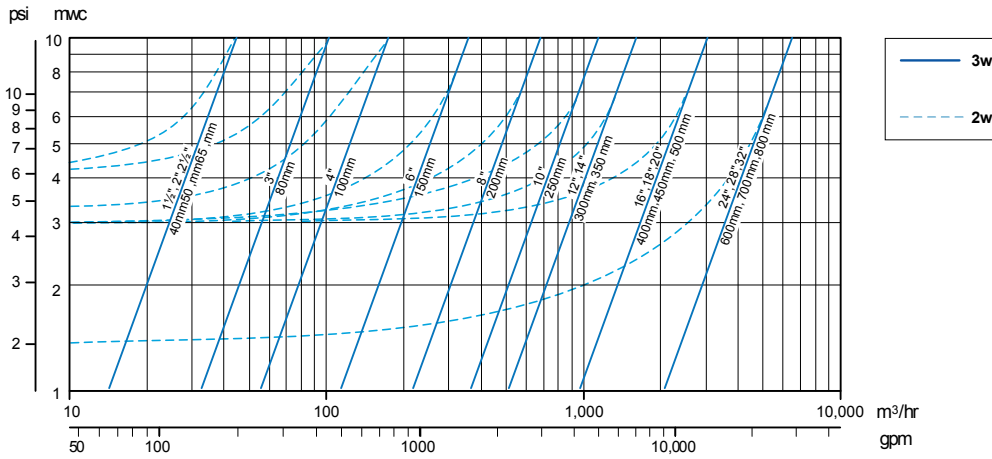

Models 30A/31A (Angle Pattern) Pressure Loss Chart

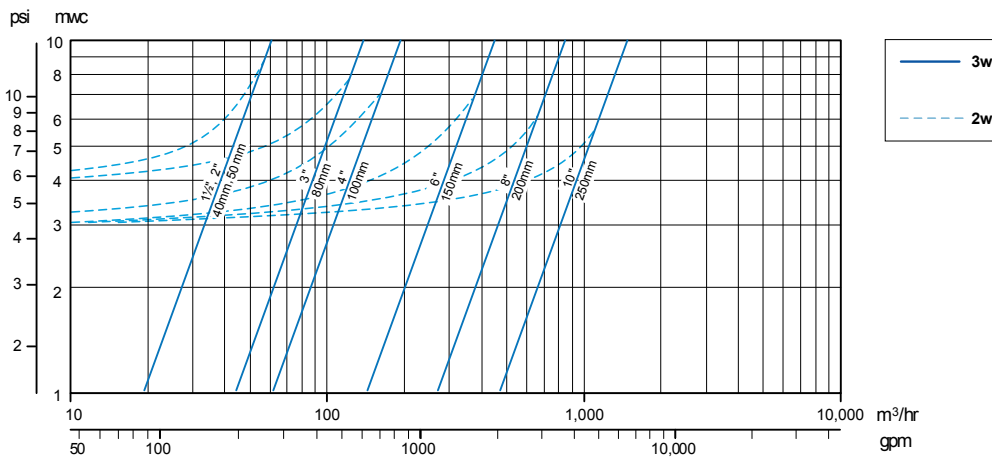

Model 32 (Globe Pattern) Pressure Loss

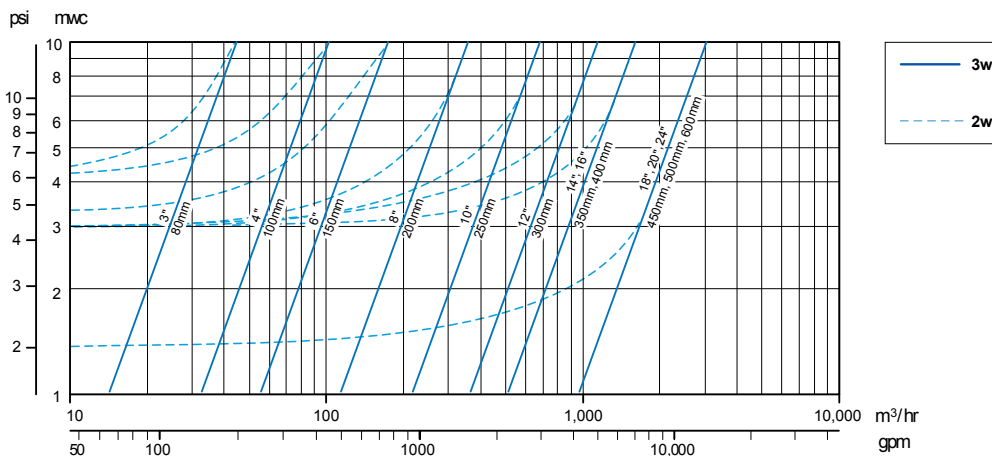

Components

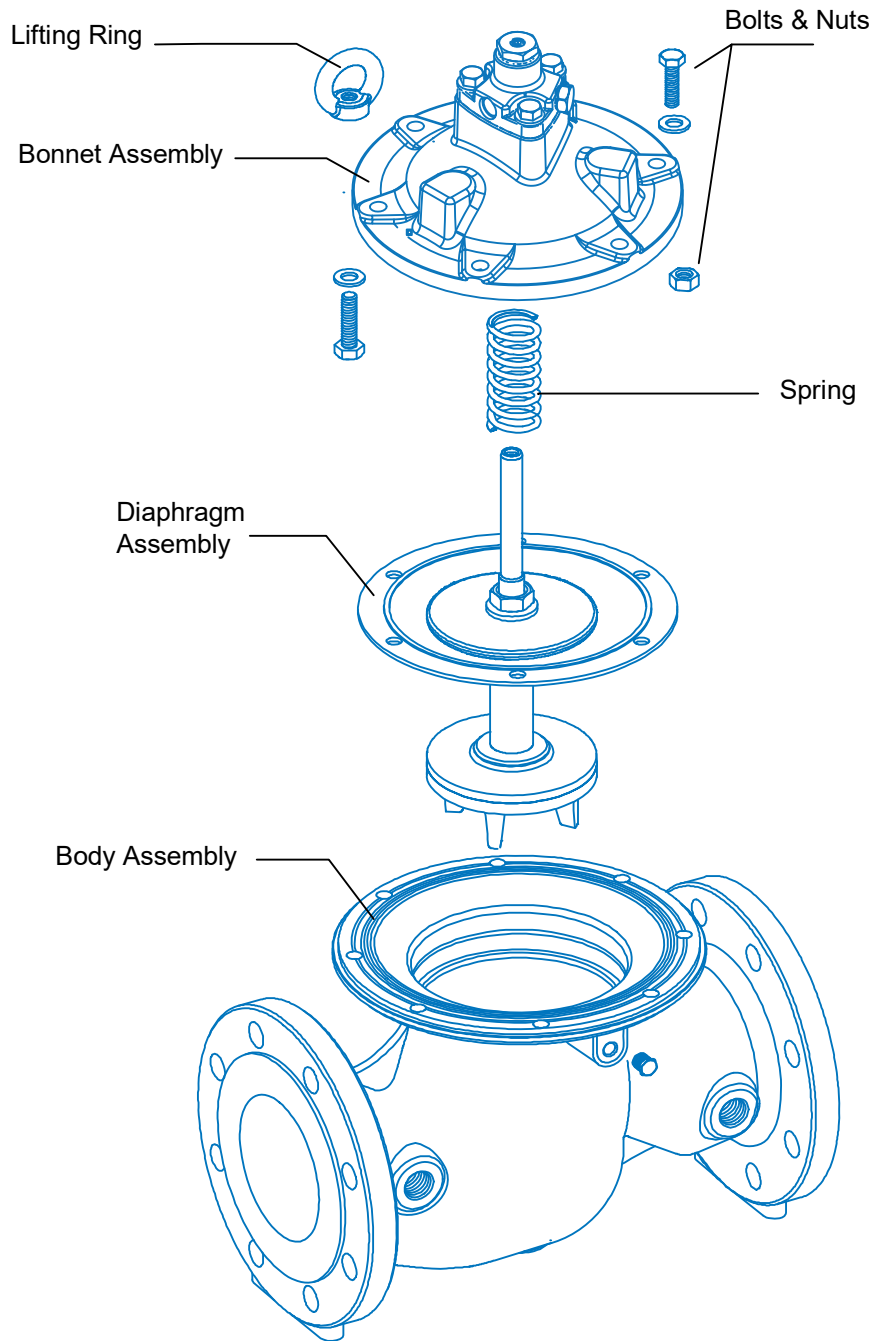
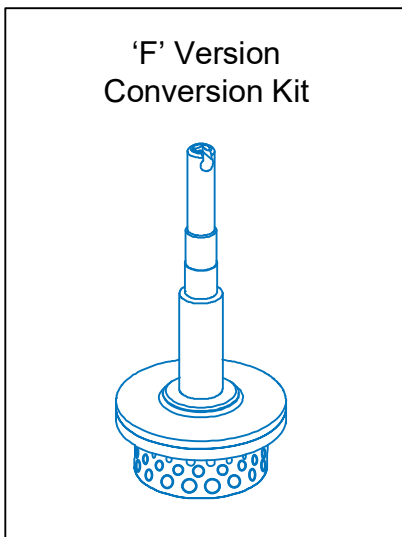
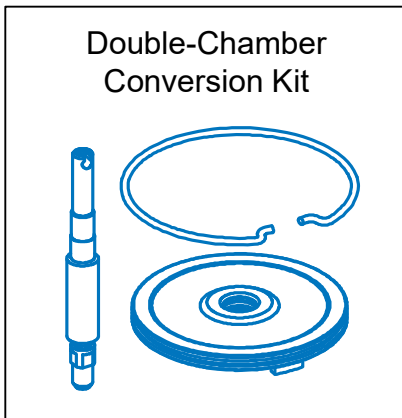
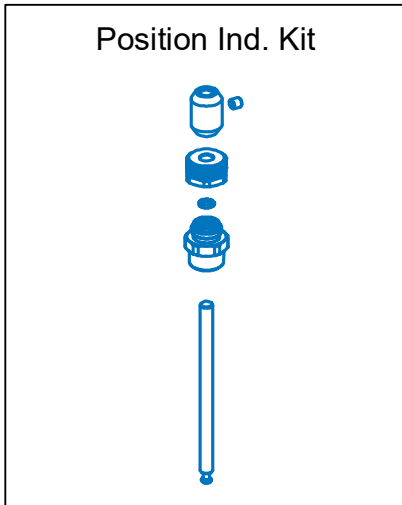

30-EL Solenoid Control Valve

Principal of operation

Dorot Series 300 Electric Control Valve ('30-EL') is an automatic, solenoid control valve, activated by the pressure of the pipeline. The valve controls by an electric current or an electric pulse, opens or closes the main valve. The standard valve is supplied in the "normally closed" position. The normally open" position is optional. Electric activation can be added to other control applications on request.



S300 Features

- Superb performance:
 - Regulates at a stable mode, regardless of valve-size, down to near-zero flow. Thus, eliminating the need for a special low flow plug-design (such as 'V-port') or a bypass valve.
 - 'Floating', low-friction internal-trim design, guided by unique LPT® device.
- High reliability:
 - All control ports are fitted with SST sleeves for preventing corrosion-blockage.
 - Pre-shaped reinforced diaphragm – for easier assembly and improved longevity.
- Reduced periodic inspection/maintenance labor:
 - The control-trim is fitted with a self-flushing, inline control-filter.
 - Easy in-situ adjustment and maintenance.
- Versatility:
 - A standard and simple single-chamber valve design, provides smooth operation. Conversion to a double chamber is a patented option.

Standard Materials

- Body & Cover – Ductile Iron
 - Optional – Cast Steel, SST, N.A.B, S.Duplex
- Main Internal – SST (1.5"-6), Coated steel (8"-32")
 - Optional – Cast Steel, SST, N.A.B, S.Duplex
- Elastomers – EPDM
 - Optional – NBR, Neoprene, Viton or others
- Coating – Polyester, Epoxy / Optional – Halar and others
- Control trim – Brass, PA / Optional – SST316, Duplex

Purchase Specifications

- The valve will be controlled by an electric solenoid valve.
- Face-to-face length dimension meets ISO 5752 Standard.
- The stem will be guided at the top by a replaceable guide bearing and at the bottom by a stainless steel unique LPT® device.
- All control ports will be fitted with stainless steel sleeves for preventing corrosion-blockage.

Design Considerations

- The valve should be suited for the maximal flow and allowed Headloss.
- Large pressure differentials may cause cavitation damage. Consult Dorot for solutions if such conditions are expected.

Quick Sizing

- Valve sized to be the same as line-size or one nominal-size smaller.
- Maximum recommended flow velocity for continuous operation 5.5 m/sec (18 ft. /sec).

Pressure rating

- Model 30, 30A for medium pressure (PN16 bar / 250 psi)
- Model 31, 31A for high pressure (PN25 bar / 360 psi)

Typical Installation

The EL valve is activated from a central control point by electric command.

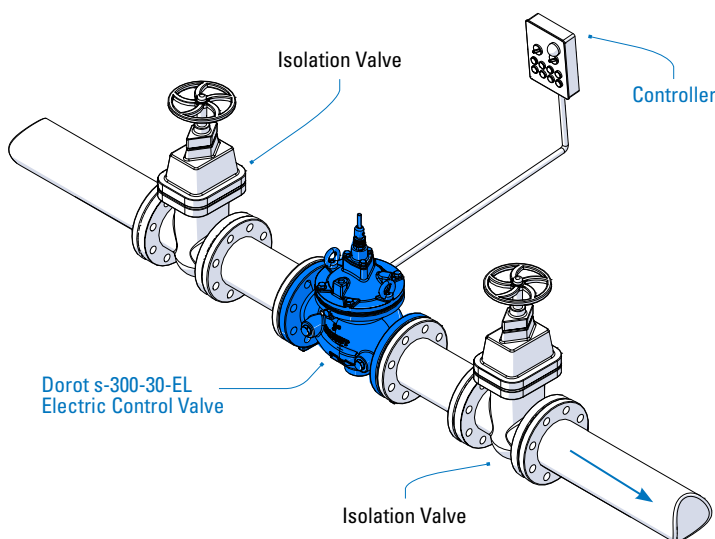

Main Control System Components*

1. Main Valve
2. Ball valve
3. Self-flushing filter
4. 3/2 Solenoid Valve
5. 66-210 Relay - Above size 8"

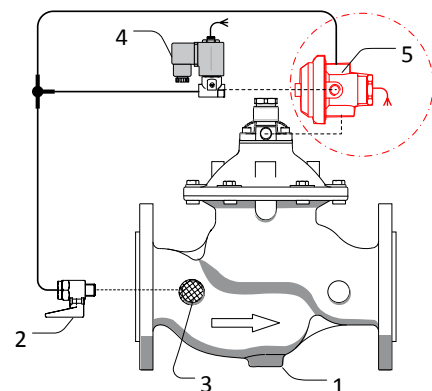

30-EL\TO Two Stage Opening Solenoid Control Valve

Principal of operation

Dorot Series 300 Electric Control Valve ('30-EL\TO') is an automatic, solenoid control valve, activated by the pressure of the pipeline. The valve controls by an electric current or an electric pulse, opens or closes the main valve. The 'TO' device prevents damage caused by too fast filling of a drained pipeline. The flow rate will be restricted, until the network, downstream of the valve is full and then a full opening of the valve is enabled.

**The 'TO' device can be added to any el control function.*



S300 Features

- Superb performance:
 - Regulates at a stable mode, regardless of valve-size, down to near-zero flow. Thus, eliminating the need for a special low flow plug-design (such as 'V-port') or a bypass valve.
 - 'Floating', low-friction internal-trim design, guided by unique LPT® device.
- High reliability:
 - All control ports are fitted with SST sleeves for preventing corrosion-blockage.
 - Pre-shaped reinforced diaphragm – for easier assembly and improved longevity.
- Reduced periodic inspection/maintenance labor:
 - The control-trim is fitted with a self-flushing, inline control-filter.
 - Easy in-situ adjustment and maintenance.
- Versatility:
 - A standard and simple single-chamber valve design, provides smooth operation. Conversion to a double chamber is a patented option.

Standard Materials

- Body & Cover – Ductile Iron
 - Optional – Cast Steel, SST, N.A.B, S.Duplex
- Main Internal – SST (1.5"-6), Coated steel (8"-32")
 - Optional – Cast Steel, SST, N.A.B, S.Duplex
- Elastomers – EPDM
 - Optional – NBR, Neoprene, Viton or others
- Coating – Polyester, Epoxy / Optional – Halar and others
- Control trim – Brass, PA / Optional – SST316, Duplex

Purchase Specifications

- The valve will be controlled by an electric solenoid valve.
- Face-to-face length dimension meets ISO 5752 Standard.
- The stem will be guided at the top by a replaceable guide bearing and at the bottom by a stainless steel unique LPT® device.
- All control ports will be fitted with stainless steel sleeves for preventing corrosion-blockage.

Design Considerations

- The valve should be suited for the maximal flow and allowed Headloss.
- Large pressure differentials may cause cavitation damage. Consult Dorot for solutions if such conditions are expected.

Quick Sizing

- Valve sized to be the same as line-size or one nominal-size smaller.
- Maximum recommended flow velocity for continuous operation 5.5 m/sec (18 ft. /sec).

Pressure rating

- Model 30, 30A for medium pressure (PN16 bar / 250 psi)
- Model 31, 31A for high pressure (PN25 bar / 360 psi)

Typical Installation

The EL\TO valve is activated from a central control point by electric command. The 'TO' device prevents damage caused by too fast filling of a drained pipeline

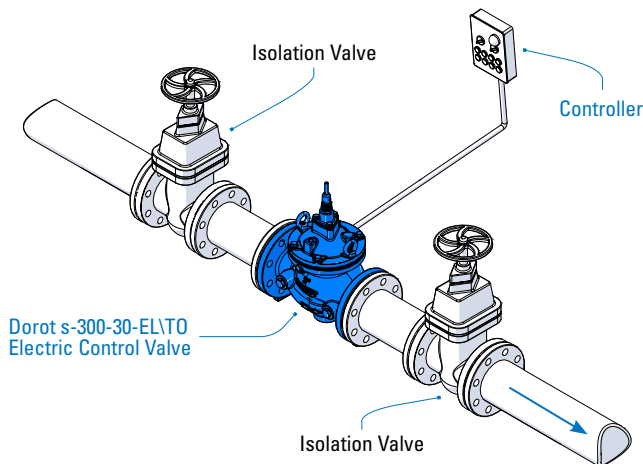

Main Control System Components*

1. Main Valve
2. Ball valve
3. Self-flushing filter
4. 3/2 Solenoid Valve
5. 66-210 Relay - Above size 8"
6. 3W PR Pilot Valve

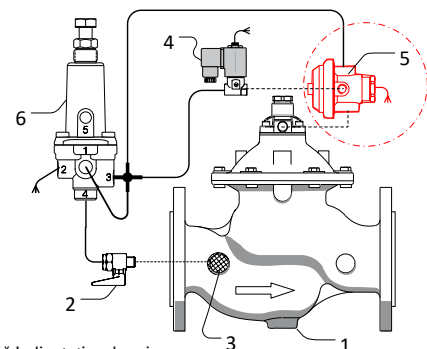

30-EC Electronic Control Valve

Principal of operation

Dorot Series 300 Electronic Control Valve ('30-EC') is an automatic, solenoid control valve, activated by the pressure of the pipeline. The valve controls by the versatile DOROT "ConDor" controller that enables all control functions, or combination of functions, at extreme accuracy. Can be controlled by any pulse-activating controller.



S300 Features

- Superb performance:
 - Regulates at a stable mode, regardless of valve-size, down to near-zero flow. Thus, eliminating the need for a special low flow plug-design (such as 'V-port') or a bypass valve.
 - 'Floating', low-friction internal-trim design, guided by unique LPT® device.
- High reliability:
 - All control ports are fitted with SST sleeves for preventing corrosion-blockage.
 - Pre-shaped reinforced diaphragm – for easier assembly and improved longevity.
- Reduced periodic inspection/maintenance labor:
 - The control-trim is fitted with a self-flushing, inline control-filter.
 - Easy in-situ adjustment and maintenance.
- Versatility:
 - A standard and simple single-chamber valve design, provides smooth operation. Conversion to a double chamber is a patented option.

Standard Materials

- Body & Cover – Ductile Iron
Optional – Cast Steel, SST, N.A.B, S.Duplex
- Main Internal – SST (1.5"-6), Coated steel (8"-32")
Optional – Cast Steel, SST, N.A.B, S.Duplex
- Elastomers – EPDM
Optional – NBR, Neoprene, Viton or others
- Coating – Polyester, Epoxy / Optional – Halar and others
- Control trim – Brass, PA / Optional – SST316, Duplex

Purchase Specifications

- The valve will be controlled by an electric solenoid valves and DOROT "ConDor" Controller.
- Face-to-face length dimension meets ISO 5752 Standard.
- The stem will be guided at the top by a replaceable guide bearing and at the bottom by a stainless steel unique LPT® device.
- All control ports will be fitted with stainless steel sleeves for preventing corrosion-blockage.

Design Considerations

- The valve should be suited for the maximal flow and allowed Headloss.
- Large pressure differentials may cause cavitation damage. Consult Dorot for solutions if such conditions are expected.

Quick Sizing

- Valve sized to be the same as line-size or one nominal-size smaller.
- Maximum recommended flow velocity for continuous operation 5.5 m/sec (18 ft. /sec).

Pressure rating

- Model 30, 30A for medium pressure (PN16 bar / 250 psi)
- Model 31, 31A for high pressure (PN25 bar / 360 psi)

Typical Installation

The EC valve, Activated by DOROT "ConDor" controller, enables all control functions, or combinations of functions, at extreme accuracy. The EC valve can be controlled by any pulse-activating controller.

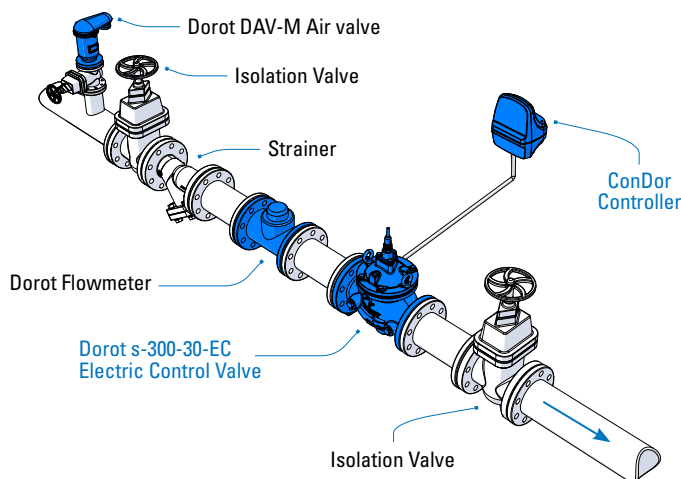

Main Control System Components*

1. Main Valve
2. Ball valve
3. Self-flushing filter
4. 2/2 Solenoid Valve
5. Check Valve

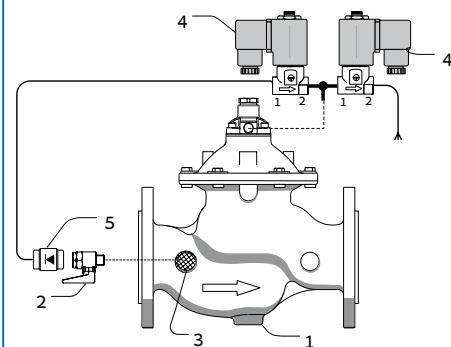

* Indicative drawing

30-PR Pressure-Reducing Valve

Principal of operation

The Dorot Series 300 Pressure-Reducing Valve ('30-PR'), activated by the pressure of the pipeline, The valve reduces high upstream-pressure to a steady, pre-determined and lower downstream pressure, regardless of fluctuations in upstream-pressure or rate of flow. In case the downstream-pressure exceeds the set value, the valve will close drip-tight.



S300 Features

- Superb performance:
 - Regulates at a stable mode, regardless of valve-size, down to near-zero flow. Thus, eliminating the need for a special low flow plug-design (such as 'V-port') or a bypass valve.
 - 'Floating', low-friction internal-trim design, guided by unique LPT® device.
- High reliability:
 - All control ports are fitted with SST sleeves for preventing corrosion-blockage.
 - Pre-shaped reinforced diaphragm – for easier assembly and improved longevity.
- Reduced periodic inspection/maintenance labor:
 - The control-trim is fitted with a self-flushing, inline control-filter.
 - Easy in-situ adjustment and maintenance.
- Versatility:
 - A standard and simple single-chamber valve design, provides smooth operation. Conversion to a double chamber is a patented option.

Standard Materials

- Body & Cover – Ductile Iron
Optional – Cast Steel, SST, N.A.B, S.Duplex
- Main Internal – SST (1.5"-6), Coated steel (8"-32")
Optional – Cast Steel, SST, N.A.B, S.Duplex
- Elastomers – EPDM
Optional – NBR, Neoprene, Viton or others
- Coating – Polyester, Epoxy / Optional – Halar and others
- Control trim – Brass, PA / Optional – SST316, Duplex

Purchase Specifications

- The valve will be hydraulic, pilot-operated globe type.
- Face-to-face length dimension meets ISO 5752 Standard.
- The stem will be guided at the top by a replaceable guide bearing and at the bottom by a stainless steel unique LPT® device.
- The valve will regulate any flow within the specified range without the need for a smaller bypass valve or throttling plug.
- All control ports will be corrosion free protected by stainless steel 316 inserts.

Design Considerations

- The valve should be suited for the maximal flow and allowed Headloss.
- In case upstream pressure may drop below the required set pressure, select a 3-way control pilot.
- Large pressure differentials may cause cavitation damage. Consult Dorot for solutions if such conditions are expected.

Quick Sizing

- Valve sized to be the same as line-size or one nominal-size smaller.
- Maximum recommended flow velocity for continuous operation 5.5 m/sec (18 ft. /sec).

Pressure rating

- Model 30, 30A for medium pressure (PN16 bar / 250 psi)
- Model 31, 31A for high pressure (PN25 bar / 360 psi)

Typical Installation

Typical applications Includes a Pressure Reducing Valve Model 30-PR. Installation of a Quick Relief Valve, model 30-QR and DAV-M air valve, downstream of the PR Valve is recommended.

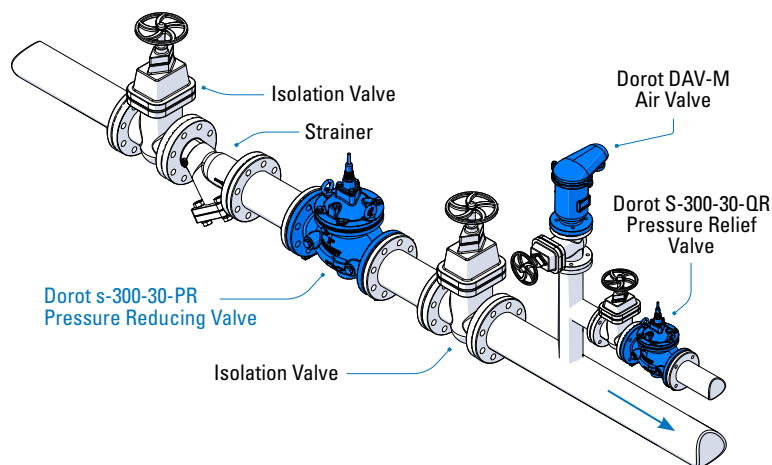

Main Control System Components*

1. Main Valve
2. Ball valve
3. Self-flushing filter
4. 2W PR Pilot Valve
5. Pressure Gauge

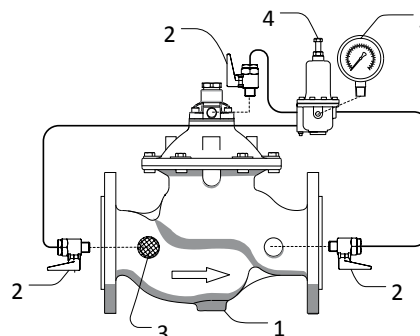

* Indicative drawing

30-PR[D] Proportional Pressure-Reducing Valve

Principal of operation

The Dorot Series 300 Proportional Pressure-Reducing Valve ('30-PR[D]'), is an automatic, proportional pressure-reducing valve. The valve is a double-chambered valve that will control the downstream pressure to vary in a fixed proportion in relation to the upstream pressure-value.



S300 Features

- Superb performance:
 - Regulates at a stable mode, regardless of valve-size, down to near-zero flow. Thus, eliminating the need for a special low flow plug-design (such as 'V-port') or a bypass valve.
 - 'Floating', low-friction internal-trim design, guided by unique LPT® device.
- High reliability:
 - All control ports are fitted with SST sleeves for preventing corrosion-blockage.
 - Pre-shaped reinforced diaphragm – for easier assembly and improved longevity.
- Reduced periodic inspection/maintenance labor:
 - The control-trim is fitted with a self-flushing, inline control-filter.
 - Easy in-situ adjustment and maintenance.
- Versatility:
 - A standard and simple single-chamber valve design, provides smooth operation. Conversion to a double chamber is a patented option.

Standard Materials

- Body & Cover – Ductile Iron
Optional – Cast Steel, SST, N.A.B, S.Duplex
- Main Internal – SST (1.5"-6), Coated steel (8"-32")
Optional – Cast Steel, SST, N.A.B, S.Duplex
- Elastomers – EPDM
Optional – NBR, Neoprene, Viton or others
- Coating – Polyester, Epoxy / Optional – Halar and others
- Control trim – Brass, PA / Optional – SST316, Duplex

Purchase Specifications

- Face-to-face length dimension meets ISO 5752 Standard.
- The stem will be guided at the top by a replaceable guide bearing and at the bottom by a stainless steel unique LPT® device.
- The valve will regulate any flow within the specified range without the need for a smaller bypass valve or throttling plug.
- All control ports will be corrosion free protected by stainless steel 316 inserts.

Design Considerations

- The valve should be suited for the maximal flow and allowed Headloss.

Quick Sizing

- Valve sized to be the same as line-size or one nominal-size smaller.
- Maximum recommended flow velocity for continuous operation 5.5 m/sec (18 ft. /sec).

Pressure rating

- Model 30, 30A for medium pressure (PN16 bar / 250 psi)
- Model 31, 31A for high pressure (PN25 bar / 360 psi)

Typical Installation

Typical applications Includes a Proportional Pressure Reducing Valve Model 30-PR[D]. Assembly of a PR[D] valve, upstream of a PR Valve, creates a two-stage, cavitation-free, pressure reducing station. Installation of a Quick Relief Valve, model 30-QR and DAV-M air valve, downstream of the PR Valve is recommended.

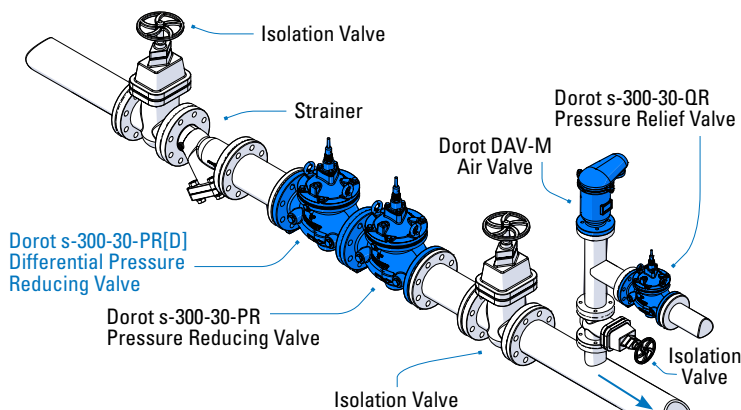

Main Control System Components*

1. Main Valve
2. Ball valve
3. Nozzle

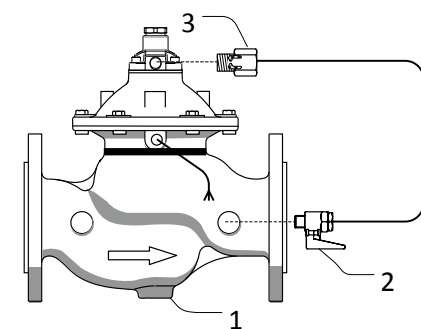

* Indicative drawing

30-PRM Dual Set-Point Pressure-Reducing Valve

Principal of operation

The Dorot Series 300 Dual set-point Pressure-Reducing ('30-PRM') valve, is an automatic, pilot controlled pressure reducing valve. The valve will regulate downstream pressure to one of two set-values. The set-value is selected by an hydraulic command sent to the control-trim of the valve. Both pressure values can be easily adjusted by the user.

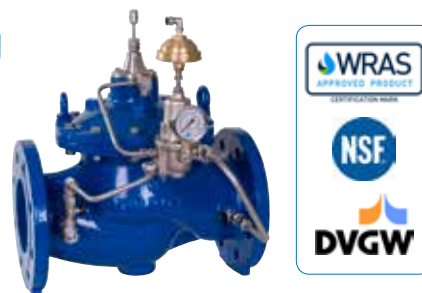

S300 Features

- Superb performance:
 - Regulates at a stable mode, regardless of valve-size, down to near-zero flow. Thus, eliminating the need for a special low flow plug-design (such as 'V-port') or a bypass valve.
 - 'Floating', low-friction internal-trim design, guided by unique LPT® device.
- High reliability:
 - All control ports are fitted with SST sleeves for preventing corrosion-blockage.
 - Pre-shaped reinforced diaphragm – for easier assembly and improved longevity.
- Reduced periodic inspection/maintenance labor:
 - The control-trim is fitted with a self-flushing, inline control-filter.
 - Easy in-situ adjustment and maintenance.
- Versatility:
 - A standard and simple single-chamber valve design, provides smooth operation. Conversion to a double chamber is a patented option.

Standard Materials

- Body & Cover – Ductile Iron
Optional – Cast Steel, SST, N.A.B, S.Duplex
- Main Internal – SST (1.5"-6), Coated steel (8"-32")
Optional – Cast Steel, SST, N.A.B, S.Duplex
- Elastomers – EPDM
Optional – NBR, Neoprene, Viton or others
- Coating – Polyester, Epoxy / Optional – Halar and others
- Control trim – Brass, PA / Optional – SST316, Duplex

Purchase Specifications

- The valve will be hydraulic, pilot-operated globe type.
- Face-to-face length dimension meets ISO 5752 Standard.
- The stem will be guided at the top by a replaceable guide bearing and at the bottom by a stainless steel unique LPT® device.
- The valve will regulate any flow within the specified range without the need for a smaller bypass valve or throttling plug.
- All control ports will be corrosion free protected by stainless steel 316 inserts.

Design Considerations

- The valve should be suited for the maximal flow and allowed Headloss.
- In case upstream pressure may drop below the required set pressure, select a 3-way control pilot.
- Large pressure differentials may cause cavitation damage. Consult Dorot for solutions if such conditions are expected.

Quick Sizing

- Valve sized to be the same as line-size or one nominal-size smaller.
- Maximum recommended flow velocity for continuous operation 5.5 m/sec (18 ft. /sec).

Pressure rating

- Model 30, 30A for medium pressure (PN16 bar / 250 psi)
- Model 31, 31A for high pressure (PN25 bar / 360 psi)

Typical Installation

Typical applications Includes a Pressure Reducing Valve Model 30-PRM Installation of a Quick Relief Valve, model 30-QR and DAV-M air valve, downstream of the PR Valve is recommended.

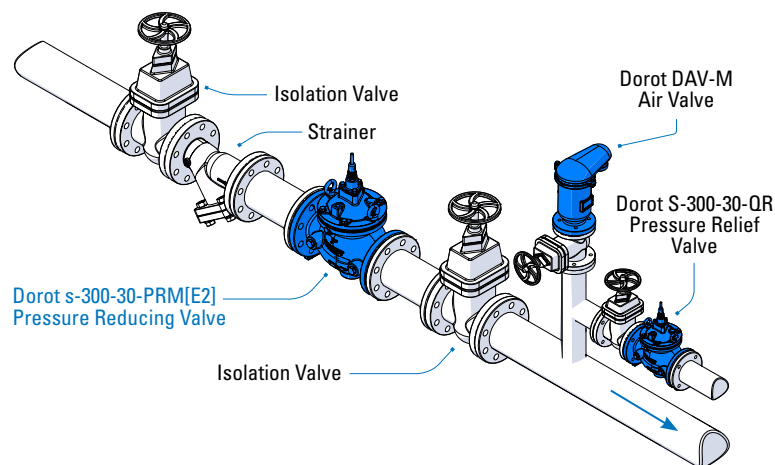

Main Control System Components*

1. Main Valve
2. Ball valve
3. Self-flushing filter
4. 2W PRM Pilot Valve
5. Pressure Gauge

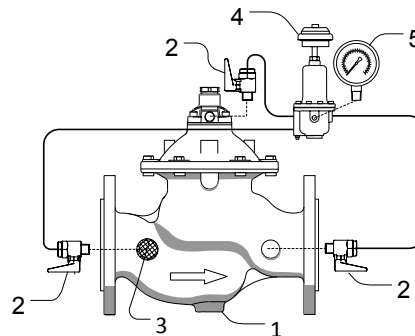

* Indicative drawing

30-HyMod Flow-Modulated Pressure-Reducing Valve

Principal of operation

Dorot model 'HyMod' is an automatic pilot controlled, flow-modulated pressure reducing valve activated by the pressure of the pipeline. The valve reduces upstream pressure to a downstream pressure that increases or decreases simultaneously with the demand flow. The pressure into the zone is continually adjusted according to the zone's actual demand, thus compensating for the system loss. The pressure-flow profile can be adjusted. The Dorot HyMod will control from no flow, to maximal full open flow without any chattering or slamming.

Features

- Superb performance:
 - Regulates at a stable mode, regardless of valve-size, down to near-zero flow. Thus, eliminating the need for a special low flow plug-design (such as 'V-port') or a bypass valve.
 - 'Floating', low-friction internal-trim design, guided by unique LPT® device.
- High reliability:
 - All control ports are fitted with SST sleeves for preventing corrosion-blockage.
 - Pre-shaped reinforced diaphragm – for easier assembly and improved longevity.
- Reduced periodic inspection/maintenance labor:
 - The control-trim is fitted with a self-flushing, inline control-filter.
 - Easy in-situ adjustment and maintenance.
- Versatility:
 - A standard and simple single-chamber valve design, provides smooth operation. Conversion to a double chamber is a patented option.

Standard Materials

- Body & Cover – Ductile Iron
Optional – Cast Steel, SST, N.A.B, S.Duplex
- Main Internal – SST (1.5"-6), Coated steel (8"-32")
Optional – Cast Steel, SST, N.A.B, S.Duplex
- Elastomers – EPDM
Optional – NBR, Neoprene, Viton or others
- Coating – Polyester, Epoxy / Optional – Halar and others
- Control trim – Brass, PA / Optional – SST316, Duplex

Typical Installation

Typical applications include Flow-Modulated Pressure Reducing Valve Model 30-HyMod. Installation of a Quick Relief Valve, model 30-QR and DAV-M air valve, downstream of the PR Valve is recommended.

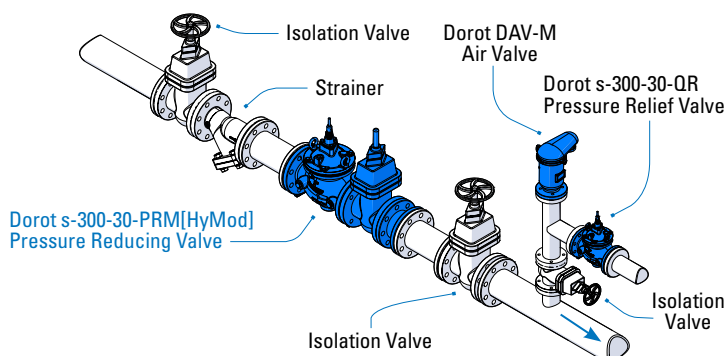

Purchase Specifications

- The valve will be hydraulic, pilot-operated globe type.
- Face-to-face length dimension meets ISO 5752 Standard.
- The stem will be guided at the top by a replaceable guide bearing and at the bottom by a stainless steel unique LPT® device.
- The valve will regulate any flow within the specified range without the need for a smaller bypass valve or throttling plug.
- All control ports will be corrosion free protected by stainless steel 316 inserts.

Design Considerations

- The valve should be suited for the maximal flow and allowed Headloss.
- In case upstream pressure may drop below the required set pressure, select a 3-way control pilot.
- Large pressure differentials may cause cavitation damage. Consult Dorot for solutions if such conditions are expected.

Quick Sizing

- Valve sized to be the same as line-size or one nominal-size smaller.
- Maximum recommended flow velocity for continuous operation 5.5 m/sec (18 ft. /sec).

Pressure rating

- Model 30, 30A for medium pressure (PN16 bar / 250 psi)
- Model 31, 31A for high pressure (PN25 bar / 360 psi)

Main Control System Components*

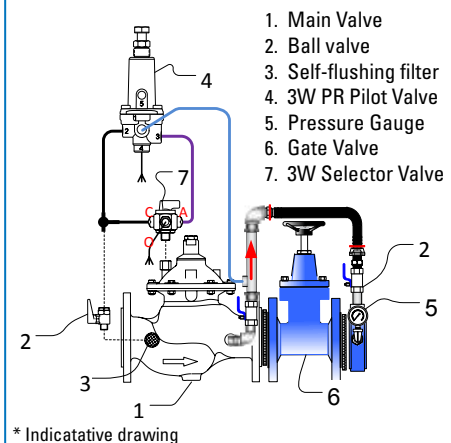

30-PS[R] Pressure-Sustaining\Relief Valve

Principal of operation

The Dorot Series 300 Pressure-Sustaining Relief Valve ('30-PS[R]') activates by the pressure of the pipeline. The valve maintains a steady, predetermined pressure in the network, upstream of its location. Should the upstream pressure exceed the required set-point, the valve opens, increasing network flow, thus reducing its upstream pressure. Should upstream pressure falls below the required value, the valve closes drip-tight.



S300 Features

- Superb performance:
 - Regulates at a stable mode, regardless of valve-size, down to near-zero flow. Thus, eliminating the need for a special low flow plug-design (such as 'V-port') or a bypass valve.
 - 'Floating', low-friction internal-trim design, guided by unique LPT® device.
- High reliability:
 - All control ports are fitted with SST sleeves for preventing corrosion-blockage.
 - Pre-shaped reinforced diaphragm – for easier assembly and improved longevity.
- Reduced periodic inspection/maintenance labor:
 - The control-trim is fitted with a self-flushing, inline control-filter.
 - Easy in-situ adjustment and maintenance.
- Versatility:
 - A standard and simple single-chamber valve design, provides smooth operation. Conversion to a double chamber is a patented option.

Standard Materials

- Body & Cover – Ductile Iron
Optional – Cast Steel, SST, N.A.B, S.Duplex
- Main Internal – SST (1.5"-6), Coated steel (8"-32")
Optional – Cast Steel, SST, N.A.B, S.Duplex
- Elastomers – EPDM
Optional – NBR, Neoprene, Viton or others
- Coating – Polyester, Epoxy / Optional – Halar and others
- Control trim – Brass, PA / Optional – SST316, Duplex

Purchase Specifications

- The valve will be hydraulic, pilot-operated globe type.
- Face-to-face length dimension meets ISO 5752 Standard.
- The stem will be guided at the top by a replaceable guide bearing and at the bottom by a stainless steel unique LPT® device.
- The valve will regulate any flow within the specified range without the need for a smaller bypass valve or throttling plug.
- All control ports will be corrosion free protected by stainless steel 316 inserts.

Design Considerations

- The valve should be suited for the maximal flow and allowed Headloss.
- Large pressure differentials may cause cavitation damage. Consult Dorot for solutions if such conditions are expected.

Quick Sizing

- Valve sized to be the same as line-size or one nominal-size smaller.
- Maximum recommended flow velocity for continuous operation 5.5 m/sec (18 ft. /sec).

Pressure rating

- Model 30, 30A for medium pressure (PN16 bar / 250 psi)
- Model 31, 31A for high pressure (PN25 bar / 360 psi)

Typical Installation

Typical applications include Pressure Sustaining Valve Model 30-PS[R]. The valve maintains the minimum required pressure in elevated demand areas, when the network flow increases, and relieves the pressure from the pipeline, when the network flow decreases.

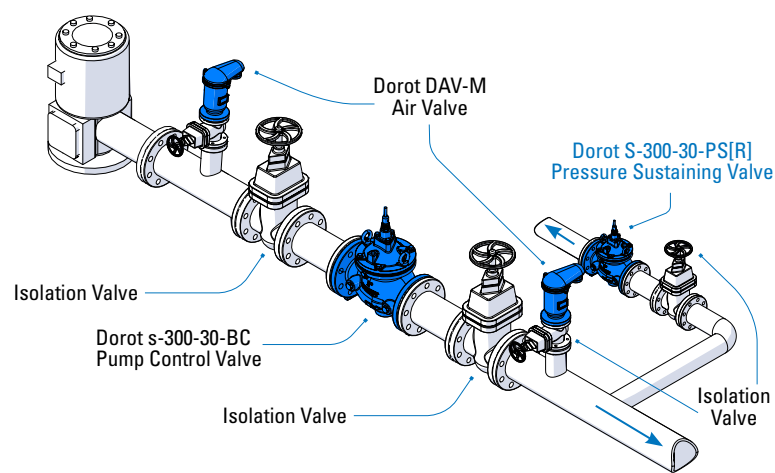

Main Control System Components*

1. Main Valve
2. Ball valve
3. Self-flushing filter
4. 2W PS Pilot Valve
5. Pressure Gauge

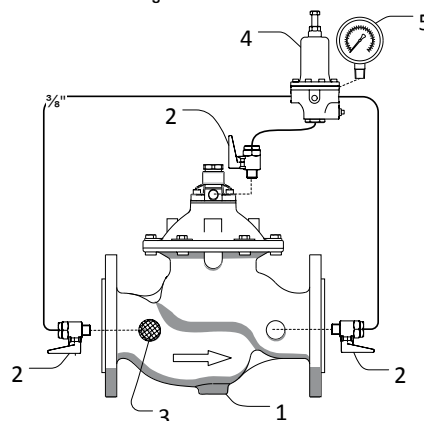

* Indicative drawing

30-PS Pressure Sustaining Valve

Principal of operation

The Dorot Series 300 Pressure-Sustaining Valve ('30-PS') activates by the pressure of the pipeline. The valve maintains a steady, predetermined pressure in the network, upstream of its location. Should the upstream pressure exceed the required set-point, the valve opens, increasing network flow, thus reducing its upstream pressure. If upstream pressure falls below the required value, the valve closes drip-tight.



S300 Features

- Superb performance:
 - Regulates at a stable mode, regardless of valve-size, down to near-zero flow. Thus, eliminating the need for a special low flow plug-design (such as 'V-port') or a bypass valve.
 - 'Floating', low-friction internal-trim design, guided by unique LPT® device.
- High reliability:
 - All control ports are fitted with SST sleeves for preventing corrosion-blockage.
 - Pre-shaped reinforced diaphragm – for easier assembly and improved longevity.
- Reduced periodic inspection/maintenance labor:
 - The control-trim is fitted with a self-flushing, inline control-filter.
 - Easy in-situ adjustment and maintenance.
- Versatility:
 - A standard and simple single-chamber valve design, provides smooth operation. Conversion to a double chamber is a patented option.

Standard Materials

- Body & Cover – Ductile Iron
Optional – Cast Steel, SST, N.A.B, S.Duplex
- Main Internal – SST (1.5"-6), Coated steel (8"-32")
Optional – Cast Steel, SST, N.A.B, S.Duplex
- Elastomers – EPDM
Optional – NBR, Neoprene, Viton or others
- Coating – Polyester, Epoxy / Optional – Halar and others
- Control trim – Brass, PA / Optional – SST316, Duplex

Purchase Specifications

- The valve will be hydraulic, pilot-operated globe type.
- Face-to-face length dimension meets ISO 5752 Standard.
- The stem will be guided at the top by a replaceable guide bearing and at the bottom by a stainless steel unique LPT® device.
- The valve will regulate any flow within the specified range without the need for a smaller bypass valve or throttling plug.
- All control ports will be corrosion free protected by stainless steel 316 inserts.

Design Considerations

- The valve should be suited for the maximal flow and allowed Headloss.
- For low pressure systems, consider a 3-way control pilots.
- Large pressure differentials may cause cavitation damage. Consult Dorot for solutions if such conditions are expected.

Quick Sizing

- Valve sized to be the same as line-size or one nominal-size smaller.
- Maximum recommended flow velocity for continuous operation 5.5 m/sec (18 ft. /sec).

Pressure rating

- Model 30, 30A for medium pressure (PN16 bar / 250 psi)
- Model 31, 31A for high pressure (PN25 bar / 360 psi)

Typical Installation

Typical applications include Pressure Sustaining Valve Model 30-PS. The valve will maintain a steady, predetermined pressure in the network, upstream of its location.

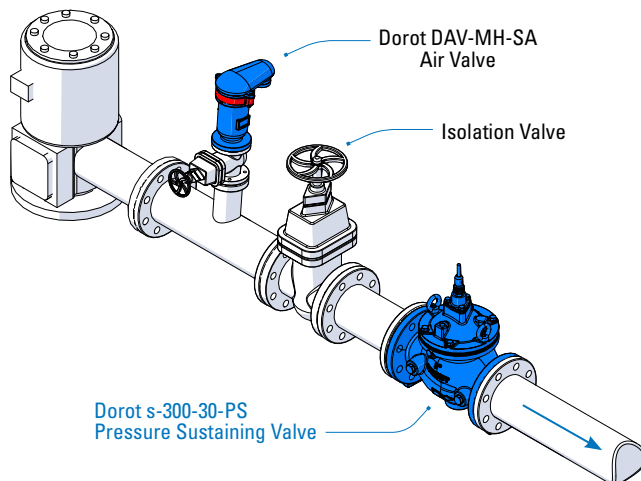

Main Control System Components*

1. Main Valve
2. Ball valve
3. Self-flushing filter
4. 2W PS Pilot Valve
5. Pressure Gauge

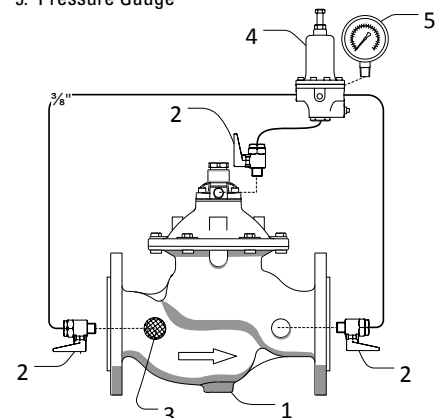

* Indicative drawing

30-PR\PS Pressure Sustaining\Reducing Valve

Principal of operation

The Dorot Series 300 Pressure Reducing and Sustaining ('30-PR\PS') activates by the pressure of the pipeline. An automatic, pilot controlled back-pressure sustaining valve and pressure reducing valve. The valve will open when the pressure reached a predetermined pressure, upstream of its location. The valve will limit the downstream pressure to a set value, regardless of upstream pressure and flow variations.



S300 Features

- Superb performance:
 - Regulates at a stable mode, regardless of valve-size, down to near-zero flow. Thus, eliminating the need for a special low flow plug-design (such as 'V-port') or a bypass valve.
 - 'Floating', low-friction internal-trim design, guided by unique LPT® device.
- High reliability:
 - All control ports are fitted with SST sleeves for preventing corrosion-blockage.
 - Pre-shaped reinforced diaphragm – for easier assembly and improved longevity.
- Reduced periodic inspection/maintenance labor:
 - The control-trim is fitted with a self-flushing, inline control-filter.
 - Easy in-situ adjustment and maintenance.
- Versatility:
 - A standard and simple single-chamber valve design, provides smooth operation. Conversion to a double chamber is a patented option.

Standard Materials

- Body & Cover – Ductile Iron
Optional – Cast Steel, SST, N.A.B, S.Duplex
- Main Internal – SST (1.5"-6), Coated steel (8"-32")
Optional – Cast Steel, SST, N.A.B, S.Duplex
- Elastomers – EPDM
Optional – NBR, Neoprene, Viton or others
- Coating – Polyester, Epoxy / Optional – Halar and others
- Control trim – Brass, PA / Optional – SST316, Duplex

Purchase Specifications

- The valve will be hydraulic, pilot-operated globe type.
- Face-to-face length dimension meets ISO 5752 Standard.
- The stem will be guided at the top by a replaceable guide bearing and at the bottom by a stainless steel unique LPT® device.
- The valve will regulate any flow within the specified range without the need for a smaller bypass valve or throttling plug.
- All control ports will be corrosion free protected by stainless steel 316 inserts.

Design Considerations

- The valve should be suited for the maximal flow and allowed Headloss.
- For low pressure systems, consider a 3-way control pilots.
- Large pressure differentials may cause cavitation damage. Consult Dorot for solutions if such conditions are expected.

Quick Sizing

- Valve sized to be the same as line-size or one nominal-size smaller.
- Maximum recommended flow velocity for continuous operation 5.5 m/sec (18 ft. /sec).

Pressure rating

- Model 30, 30A for medium pressure (PN16 bar / 250 psi)
- Model 31, 31A for high pressure (PN25 bar / 360 psi)

Typical Installation

Typical applications include Pressure Reducing and Sustaining Valve Model 30-PR\PS. The valve will open when the pressure reached a predetermined pressure, upstream of its location. The valve will limit the downstream pressure to a set value, regardless of upstream pressure and flow variations. Installation of a Quick Relief Valve, model 30-QR and DAV-M air valve, downstream of the PR Valve is recommended.

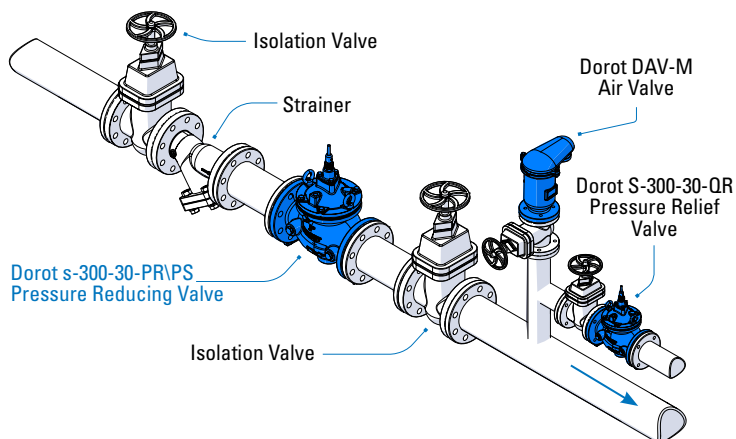

Main Control System Components*

1. Main Valve
2. Ball valve
3. Self-flushing filter
4. 2W PS Pilot Valve
5. 2W PR Pilot Valve
6. Pressure Gauge

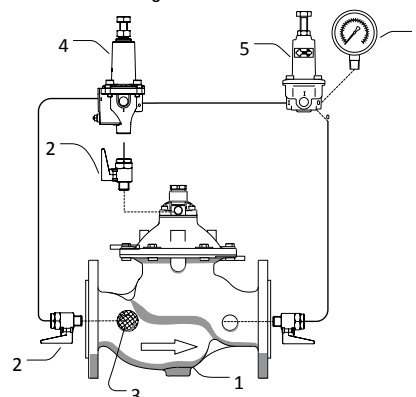

* Indicative drawing

30-DI Pressure Differential Sustaining Valve

Principal of operation

The Dorot Series 300 Pressure Differential Sustaining Valve ('30-DI') activates by the pressure of the pipeline. The valve maintains a preset pressure differential between its upstream and downstream sides. The valve can control booster pump discharge, heating and cooling systems, bypass configurations, filters and other similar systems.



S300 Features

- Superb performance:
 - Regulates at a stable mode, regardless of valve-size, down to near-zero flow. Thus, eliminating the need for a special low flow plug-design (such as 'V-port') or a bypass valve.
 - 'Floating', low-friction internal-trim design, guided by unique LPT® device.
- High reliability:
 - All control ports are fitted with SST sleeves for preventing corrosion-blockage.
 - Pre-shaped reinforced diaphragm – for easier assembly and improved longevity.
- Reduced periodic inspection/maintenance labor:
 - The control-trim is fitted with a self-flushing, inline control-filter.
 - Easy in-situ adjustment and maintenance.
- Versatility:
 - A standard and simple single-chamber valve design, provides smooth operation. Conversion to a double chamber is a patented option.

Standard Materials

- Body & Cover – Ductile Iron
Optional – Cast Steel, SST, N.A.B, S.Duplex
- Main Internal – SST (1.5"-6), Coated steel (8"-32")
Optional – Cast Steel, SST, N.A.B, S.Duplex
- Elastomers – EPDM
Optional – NBR, Neoprene, Viton or others
- Coating – Polyester, Epoxy / Optional – Halar and others
- Control trim – Brass, PA / Optional – SST316, Duplex

Purchase Specifications

- The valve will be hydraulic, pilot-operated globe type.
- Face-to-face length dimension meets ISO 5752 Standard.
- The stem will be guided at the top by a replaceable guide bearing and at the bottom by a stainless steel unique LPT® device.
- The valve will regulate any flow within the specified range without the need for a smaller bypass valve or throttling plug.
- All control ports will be corrosion free protected by stainless steel 316 inserts.

Design Considerations

- The valve should be suited for the maximal flow and allowed Headloss.
- For low pressure systems, consider a 3-way control pilots.
- Large pressure differentials may cause cavitation damage. Consult Dorot for solutions if such conditions are expected.

Quick Sizing

- Valve sized to be the same as line-size or one nominal-size smaller.
- Maximum recommended flow velocity for continuous operation 5.5 m/sec (18 ft. /sec).

Pressure rating

- Model 30, 30A for medium pressure (PN16 bar / 250 psi)
- Model 31, 31A for high pressure (PN25 bar / 360 psi)

Typical Installation

Typical applications include Pressure Differential Sustaining Valve Model 30-DI. Dorot Pressure Differential Sustaining Valve controls the flow at the discharge of a booster pump whose suction pressure varies.

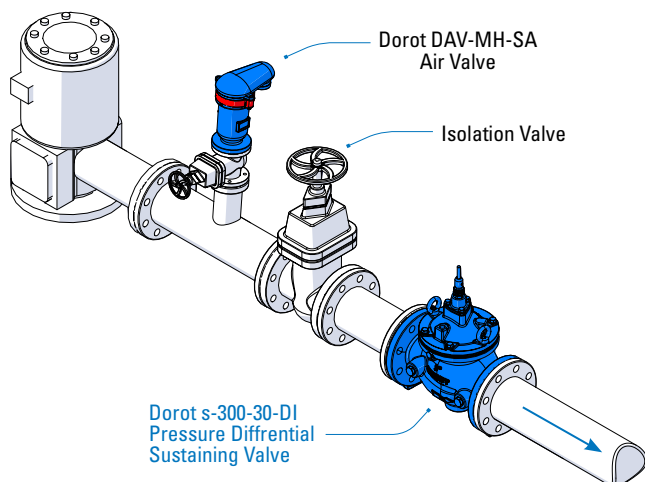

Main Control System Components*

1. Main Valve
2. Ball valve
3. Self-flushing filter
4. 2W CXSD Pilot Valve

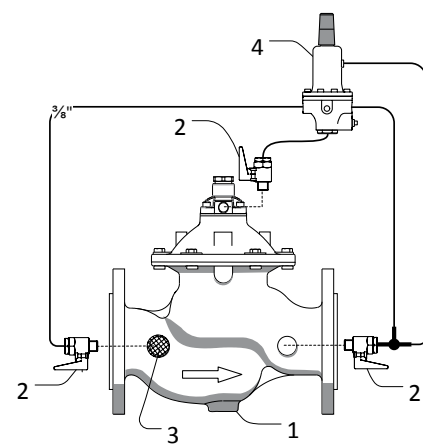

* Indicative drawing

30-FR Flow Control Valve

Principal of operation

The Dorot Series 300 Flow Control Valve ('30-FR') activates by the pressure of the pipeline. The valve limits the flow rate in the network to a preset value regardless of upstream pressure variations. The valve fully opens when the flow rate drops below the set point.



S300 Features

- Superb performance:
 - Regulates at a stable mode, regardless of valve-size, down to near-zero flow. Thus, eliminating the need for a special low flow plug-design (such as 'V-port') or a bypass valve.
 - 'Floating', low-friction internal-trim design, guided by unique LPT® device.
- High reliability:
 - All control ports are fitted with SST sleeves for preventing corrosion-blockage.
 - Pre-shaped reinforced diaphragm – for easier assembly and improved longevity.
- Reduced periodic inspection/maintenance labor:
 - The control-trim is fitted with a self-flushing, inline control-filter.
 - Easy in-situ adjustment and maintenance.
- Versatility:
 - A standard and simple single-chamber valve design, provides smooth operation. Conversion to a double chamber is a patented option.

Standard Materials

- Body & Cover – Ductile Iron
Optional – Cast Steel, SST, N.A.B, S.Duplex
- Main Internal – SST (1.5"-6), Coated steel (8"-32")
Optional – Cast Steel, SST, N.A.B, S.Duplex
- Elastomers – EPDM
Optional – NBR, Neoprene, Viton or others
- Coating – Polyester, Epoxy / Optional – Halar and others
- Control trim – Brass, PA / Optional – SST316, Duplex

Purchase Specifications

- The valve will be hydraulic, pilot-operated globe type.
- Face-to-face length dimension meets ISO 5752 Standard.
- The stem will be guided at the top by a replaceable guide bearing and at the bottom by a stainless steel unique LPT® device.
- The valve will regulate any flow within the specified range without the need for a smaller bypass valve or throttling plug.
- All control ports will be corrosion free protected by stainless steel 316 inserts.

Design Considerations

- The valve should be suited for the maximal flow and allowed Headloss.
- For low pressure systems, consider a 3-way control pilots.

Quick Sizing

- Valve sized to be the same as line-size or one nominal-size smaller.
- Maximum recommended flow velocity for continuous operation 5.5 m/sec (18 ft. /sec).

Pressure rating

- Model 30, 30A for medium pressure (PN16 bar / 250 psi)
- Model 31, 31A for high pressure (PN25 bar / 360 psi)

Typical Installation

Typical applications include Flow Control Valve Model 30-FR. The Valve limits the flow to a specific customer.

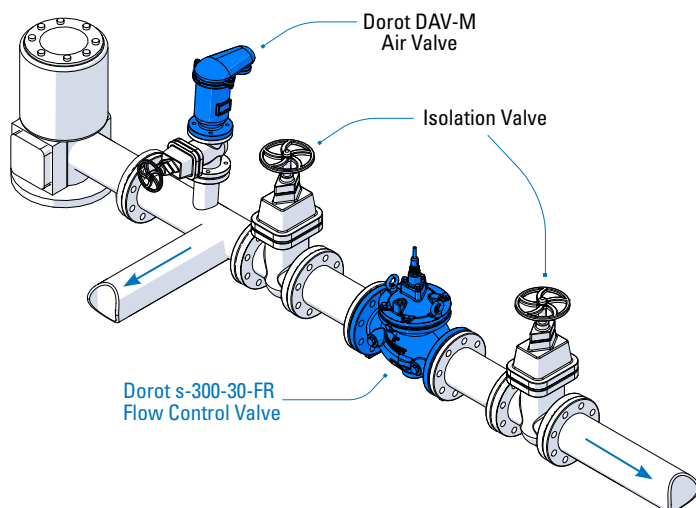

Main Control System Components*

1. Main Valve
2. Ball valve
3. Self-flushing filter
4. CXSD Pilot Valve
5. Nozzle
6. Orifice plate

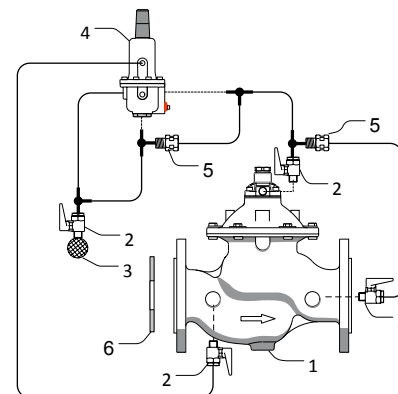

* Indicative drawing

30-FR\EL Flow Control Valve

Principal of operation

The Dorot Series 300 Electric Flow Control Valve ('30-FR\EL') activates by the pressure of the pipeline. The valve will maintain a closed position and will regulate the flow to a steady, predetermined value when the solenoid-valve is energized.



S300 Features

- Superb performance:
 - Regulates at a stable mode, regardless of valve-size, down to near-zero flow. Thus, eliminating the need for a special low flow plug-design (such as 'V-port') or a bypass valve.
 - 'Floating', low-friction internal-trim design, guided by unique LPT® device.
- High reliability:
 - All control ports are fitted with SST sleeves for preventing corrosion-blockage.
 - Pre-shaped reinforced diaphragm – for easier assembly and improved longevity.
- Reduced periodic inspection/maintenance labor:
 - The control-trim is fitted with a self-flushing, inline control-filter.
 - Easy in-situ adjustment and maintenance.
- Versatility:
 - A standard and simple single-chamber valve design, provides smooth operation. Conversion to a double chamber is a patented option.

Standard Materials

- Body & Cover – Ductile Iron
Optional – Cast Steel, SST, N.A.B, S.Duplex
- Main Internal – SST (1.5"-6), Coated steel (8"-32")
Optional – Cast Steel, SST, N.A.B, S.Duplex
- Elastomers – EPDM
Optional – NBR, Neoprene, Viton or others
- Coating – Polyester, Epoxy / Optional – Halar and others
- Control trim – Brass, PA / Optional – SST316, Duplex

Purchase Specifications

- The valve will be hydraulic, pilot-operated globe type.
- Face-to-face length dimension meets ISO 5752 Standard.
- The stem will be guided at the top by a replaceable guide bearing and at the bottom by a stainless steel unique LPT® device.
- The valve will regulate any flow within the specified range without the need for a smaller bypass valve or throttling plug.
- All control ports will be corrosion free protected by stainless steel 316 inserts.

Design Considerations

- The valve should be suited for the maximal flow and allowed Headloss.
- For low pressure systems, consider a 3-way control pilots.
- Large pressure differentials may cause cavitation damage. Consult Dorot for solutions if such conditions are expected.

Quick Sizing

- Valve sized to be the same as line-size or one nominal-size smaller.
- Maximum recommended flow velocity for continuous operation 5.5 m/sec (18 ft. /sec).

Pressure rating

- Model 30, 30A for medium pressure (PN16 bar / 250 psi)
- Model 31, 31A for high pressure (PN25 bar / 360 psi)

Typical Installation

Typical applications include Flow Control Valve Model 30-FR\EL. The Valve limits the flow to a specific customer.

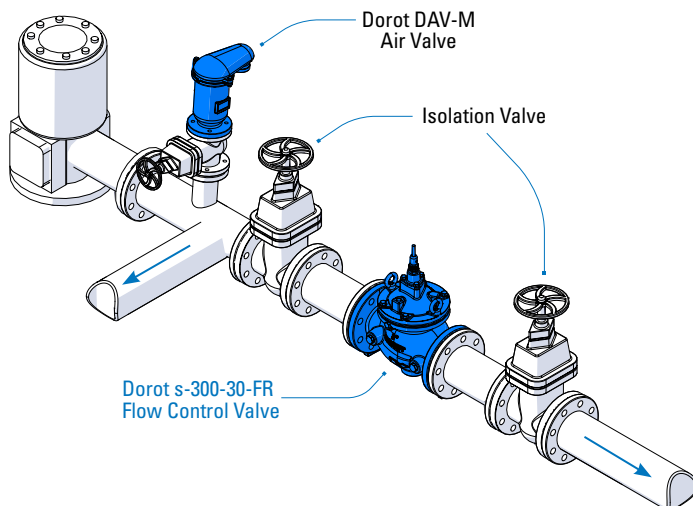

Main Control System Components*

1. Main Valve
2. Ball valve
3. Self-flushing filter
4. CXSD Pilot Valve
5. Nozzle
6. Orifice plate
7. 28-200 Relay
8. NO Solenoid valve

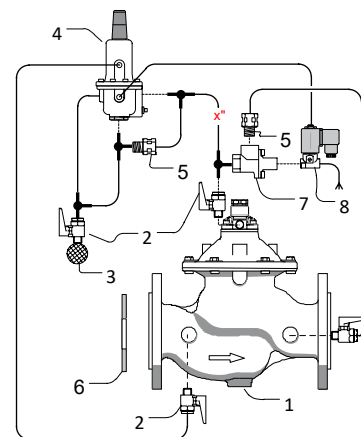

* Indicative drawing

30-FL Modulating Float Valve

Principal of operation

The Dorot Series 300 Modulating Float Valve ('30-FL') activates by the pressure of the pipeline. The valve will modulate to maintain a steady, predetermined level in the reservoir and will keep a drip-tight close position in case the level is higher than the float-pilot location.



S300 Features

- Superb performance:
 - Regulates at a stable mode, regardless of valve-size, down to near-zero flow. Thus, eliminating the need for a special low flow plug-design (such as 'V-port') or a bypass valve.
 - 'Floating', low-friction internal-trim design, guided by unique LPT® device.
- High reliability:
 - All control ports are fitted with SST sleeves for preventing corrosion-blockage.
 - Pre-shaped reinforced diaphragm – for easier assembly and improved longevity.
- Reduced periodic inspection/maintenance labor:
 - The control-trim is fitted with a self-flushing, inline control-filter.
 - Easy in-situ adjustment and maintenance.
- Versatility:
 - A standard and simple single-chamber valve design, provides smooth operation. Conversion to a double chamber is a patented option.

Standard Materials

- Body & Cover – Ductile Iron
Optional – Cast Steel, SST, N.A.B, S.Duplex
- Main Internal – SST (1.5"-6), Coated steel (8"-32")
Optional – Cast Steel, SST, N.A.B, S.Duplex
- Elastomers – EPDM
Optional – NBR, Neoprene, Viton or others
- Coating – Polyester, Epoxy / Optional – Halar and others
- Control trim – Brass, PA / Optional – SST316, Duplex

Purchase Specifications

- The valve will be hydraulic, pilot-operated globe type.
- Face-to-face length dimension meets ISO 5752 Standard.
- The stem will be guided at the top by a replaceable guide bearing and at the bottom by a stainless steel unique LPT® device.
- The valve will regulate any flow within the specified range without the need for a smaller bypass valve or throttling plug.
- All control ports will be corrosion free protected by stainless steel 316 inserts.

Design Considerations

- The valve should be suited for the maximal flow and allowed Headloss.
- In case upstream pressure may drop below the required set pressure, select a 4-way control pilot.
- Large pressure differentials may cause cavitation damage. Consult Dorot for solutions if such conditions are expected.

Quick Sizing

- Valve sized to be the same as line-size or one nominal-size smaller.
- Maximum recommended flow velocity for continuous operation 5.5 m/sec (18 ft. /sec).

Pressure rating

- Model 30, 30A for medium pressure (PN16 bar / 250 psi)
- Model 31, 31A for high pressure (PN25 bar / 360 psi)

Typical Installation

Typical applications include a Modulating Float Valve Model 30-FL. The valve will modulate to maintain a steady, predetermined level in the reservoir.
(Integrated features such as Flow control, cavitation and water hammer protections are available)

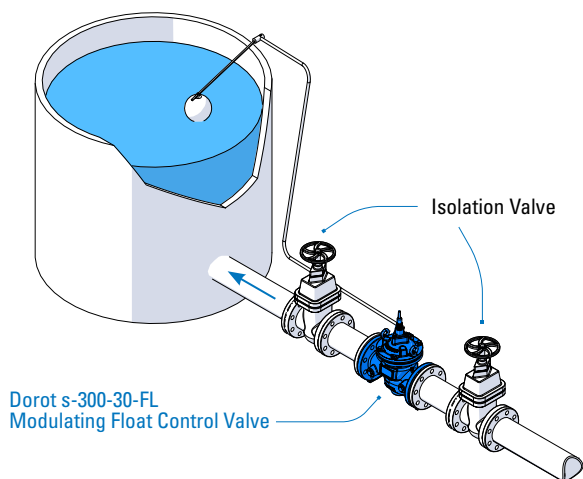

Main Control System Components*

1. Main Valve
2. Ball valve
3. Self-flushing filter
4. 2W FL Pilot Valve
5. Orifice

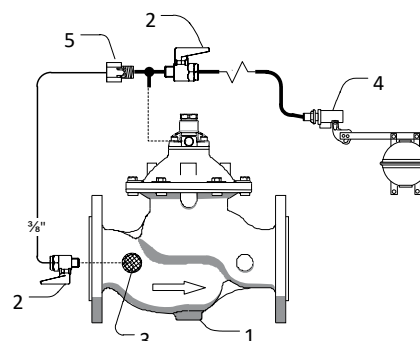

* Indicative drawing

30-FLEL Electric Float Controlled Valve

Principal of operation

The Dorot Series 300 Electric Float Control Valve ('30-FLEL') is an automatic, solenoid controlled valve, activated by the pressure of the pipeline. The valve will open at low level by an electric command from an electric float. When the level reached its high set value, the valve will close drip tight.



*optional 'FR (PR)' Flow control function.

S300 Features

- Superb performance:
 - Regulates at a stable mode, regardless of valve-size, down to near-zero flow. Thus, eliminating the need for a special low flow plug-design (such as 'V-port') or a bypass valve.
 - 'Floating', low-friction internal-trim design, guided by unique LPT® device.
- High reliability:
 - All control ports are fitted with SST sleeves for preventing corrosion-blockage.
 - Pre-shaped reinforced diaphragm – for easier assembly and improved longevity.
- Reduced periodic inspection/maintenance labor:
 - The control-trim is fitted with a self-flushing, inline control-filter.
 - Easy in-situ adjustment and maintenance.
- Versatility:
 - A standard and simple single-chamber valve design, provides smooth operation. Conversion to a double chamber is a patented option.

Standard Materials

- Body & Cover – Ductile Iron
Optional – Cast Steel, SST, N.A.B, S.Duplex
- Main Internal – SST (1.5"-6), Coated steel (8"-32")
Optional – Cast Steel, SST, N.A.B, S.Duplex
- Elastomers – EPDM
Optional – NBR, Neoprene, Viton or others
- Coating – Polyester, Epoxy / Optional – Halar and others
- Control trim – Brass, PA / Optional – SST316, Duplex

Purchase Specifications

- Face-to-face length dimension meets ISO 5752 Standard.
- The stem will be guided at the top by a replaceable guide bearing and at the bottom by a stainless steel unique LPT® device.
- The valve will regulate any flow within the specified range without the need for a smaller bypass valve or throttling plug.
- All control ports will be corrosion free protected by stainless steel 316 inserts.

Design Considerations

- The valve should be suited for the maximal flow and allowed Headloss.
- In case upstream pressure may drop below the required set pressure, select a 3-way control pilot.
- Large pressure differentials may cause cavitation damage. Consult Dorot for solutions if such conditions are expected.

Quick Sizing

- Valve sized to be the same as line-size or one nominal-size smaller.
- Maximum recommended flow velocity for continuous operation 5.5 m/sec (18 ft. /sec).

Pressure rating

- Model 30, 30A for medium pressure (PN16 bar / 250 psi)
- Model 31, 31A for high pressure (PN25 bar / 360 psi)

Typical Installation

Typical application include Electric float Valve model 30-FLEL. The valve will open at low level and close at high level by an electric command from an electric float.
(Integral features such as Flow control, cavitation and water hammer protections are available)

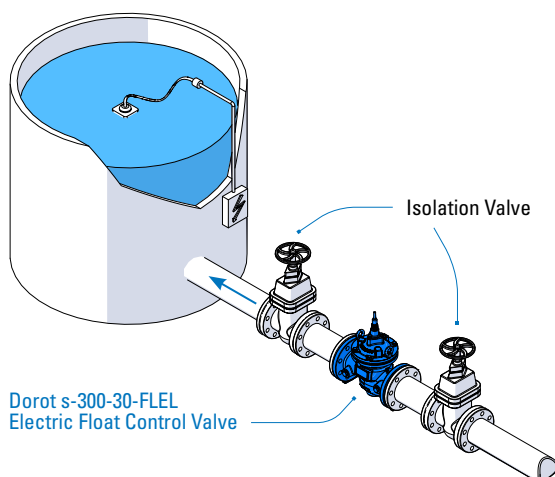

Main Control System Components*

1. Main Valve
2. Ball valve
3. Self-flushing filter
4. Electric Float
5. 3W Solenoid Valve
6. Orifice (Optional)

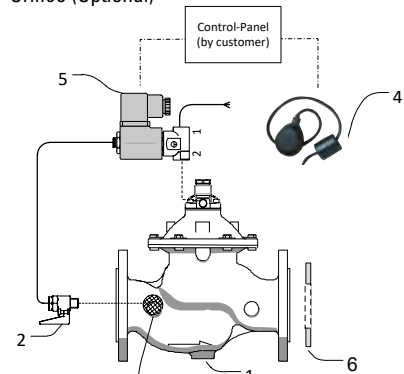

* Indicative drawing

30-FLDI Differential Float Valve

Principal of operation

The Dorot Series 300 Differential Float Valve ('30-FLDI') is an automatic, pilot controlled, level control valve, activated by the pressure of the pipeline. The valve closes when the water rises to the requested maximum level and opens when the water level drops to the preset minimum point. The differential between opening and closing levels is adjustable.

**Optional Addition: FLDISP Stepped Surge-Preventing Closure or 'FR (PR)' Flow control function.*



S300 Features

- Superb performance:
 - Regulates at a stable mode, regardless of valve-size, down to near-zero flow. Thus, eliminating the need for a special low flow plug-design (such as 'V-port') or a bypass valve.
 - 'Floating', low-friction internal-trim design, guided by unique LPT® device.
- High reliability:
 - All control ports are fitted with SST sleeves for preventing corrosion-blockage.
 - Pre-shaped reinforced diaphragm – for easier assembly and improved longevity.
- Reduced periodic inspection/maintenance labor:
 - The control-trim is fitted with a self-flushing, inline control-filter.
 - Easy in-situ adjustment and maintenance.
- Versatility:
 - A standard and simple single-chamber valve design, provides smooth operation. Conversion to a double chamber is a patented option.

Standard Materials

- Body & Cover – Ductile Iron
Optional – Cast Steel, SST, N.A.B, S.Duplex
- Main Internal – SST (1.5"-6), Coated steel (8"-32")
Optional – Cast Steel, SST, N.A.B, S.Duplex
- Elastomers – EPDM
Optional – NBR, Neoprene, Viton or others
- Coating – Polyester, Epoxy / Optional – Halar and others
- Control trim – Brass, PA / Optional – SST316, Duplex

Purchase Specifications

- The valve will be hydraulic, pilot-operated globe type.
- Face-to-face length dimension meets ISO 5752 Standard.
- The stem will be guided at the top by a replaceable guide bearing and at the bottom by a stainless steel unique LPT® device.
- The valve will regulate any flow within the specified range without the need for a smaller bypass valve or throttling plug.
- All control ports will be corrosion free protected by stainless steel 316 inserts.

Design Considerations

- The valve should be suited for the maximal flow and allowed Headloss.
- Large pressure differentials may cause cavitation damage. Consult Dorot for solutions if such conditions are expected.

Quick Sizing

- Valve sized to be the same as line-size or one nominal-size smaller.
- Maximum recommended flow velocity for continuous operation 5.5 m/sec (18 ft. /sec).

Pressure rating

- Model 30, 30A for medium pressure (PN16 bar / 250 psi)
- Model 31, 31A for high pressure (PN25 bar / 360 psi)

Typical Installation

Typical applications include a Differential Float Valve Model 30-FLDI. The valve will open when the level reached a set opening height and close on a set lower/higher level. (Integrated features such as Flow control, cavitation and water hammer protections are available)

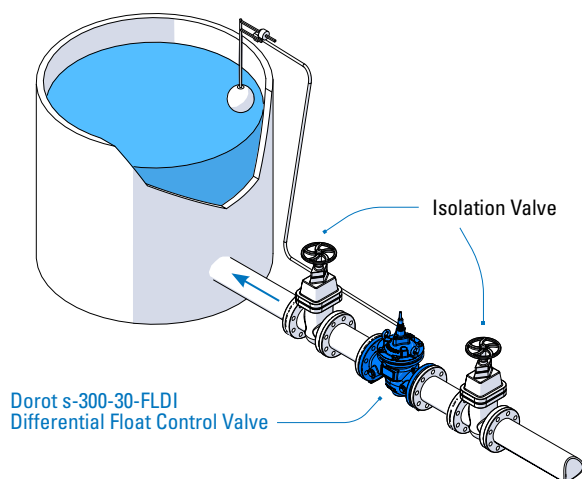

Main Control System Components*

1. Main Valve
2. Ball valve
3. Self-flushing filter
4. 3W FLDI Pilot Valve
5. 3W Ball valve
6. Orifice (Optional)

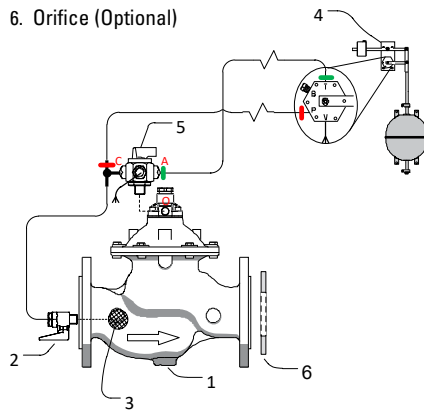

* Indicative drawing

30-FLDI\PS Differential Float and Pressure Sustaining Valve

Principal of operation

The Dorot Series 300 Differential Float and Pressure sustaining Valve ('30-FLDI\PS') is An automatic, float actuated and pressure sustaining pilot controlled valve. The valve will open and sustain a minimal required upstream-pressure when the level reached a set opening height and close on a set lower/higher level. The differential between opening and closing levels is adjustable. In case the upstream pressure is lower than the set-value, the valve will keep a closed position, regardless of the water-level.



S300 Features

- Superb performance:
 - Regulates at a stable mode, regardless of valve-size, down to near-zero flow. Thus, eliminating the need for a special low flow plug-design (such as 'V-port') or a bypass valve.
 - 'Floating', low-friction internal-trim design, guided by unique LPT® device.
- High reliability:
 - All control ports are fitted with SST sleeves for preventing corrosion-blockage.
 - Pre-shaped reinforced diaphragm – for easier assembly and improved longevity.
- Reduced periodic inspection/maintenance labor:
 - The control-trim is fitted with a self-flushing, inline control-filter.
 - Easy in-situ adjustment and maintenance.
- Versatility:
 - A standard and simple single-chamber valve design, provides smooth operation. Conversion to a double chamber is a patented option.

Standard Materials

- Body & Cover – Ductile Iron
Optional – Cast Steel, SST, N.A.B, S.Duplex
- Main Internal – SST (1.5"-6), Coated steel (8"-32")
Optional – Cast Steel, SST, N.A.B, S.Duplex
- Elastomers – EPDM
Optional – NBR, Neoprene, Viton or others
- Coating – Polyester, Epoxy / Optional – Halar and others
- Control trim – Brass, PA / Optional – SST316, Duplex

Purchase Specifications

- The valve will be hydraulic, pilot-operated globe type.
- Face-to-face length dimension meets ISO 5752 Standard.
- The stem will be guided at the top by a replaceable guide bearing and at the bottom by a stainless steel unique LPT® device.
- The valve will regulate any flow within the specified range without the need for a smaller bypass valve or throttling plug.
- All control ports will be corrosion free protected by stainless steel 316 inserts.

Design Considerations

- The valve should be suited for the maximal flow and allowed Headloss.
- For low pressure systems, consider a 3-way control pilots.
- Large pressure differentials may cause cavitation damage. Consult Dorot for solutions if such conditions are expected.

Quick Sizing

- Valve sized to be the same as line-size or one nominal-size smaller.
- Maximum recommended flow velocity for continuous operation 5.5 m/sec (18 ft. /sec).

Pressure rating

- Model 30, 30A for medium pressure (PN16 bar / 250 psi)
- Model 31, 31A for high pressure (PN25 bar / 360 psi)

Typical Installation

Typical applications include a Differential Float Valve Model 30-FLDI\PS. The valve will open and sustain a minimal required upstream-pressure when the level reached a set opening height and close on a set lower/higher level.

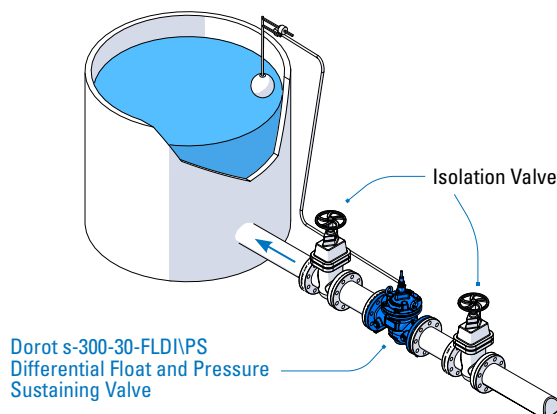

Main Control System Components*

1. Main Valve
2. Ball valve
3. Self-flushing filter
4. 3W FLDI Pilot Valve
5. 3W Ball valve
6. Orifice (Optional)
7. 31-10SD Pilot
8. Pressure gauge

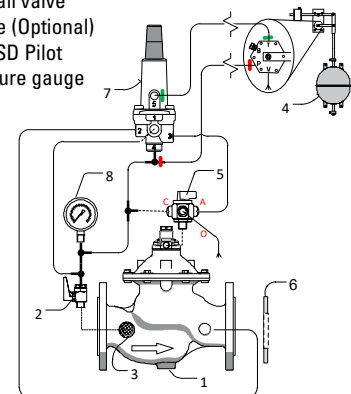

* Indicative drawing

30-FLDI\FR(PR) Differential Float and Flow Control Valve

Principal of operation

The Dorot Series 300 Differential Float and Pressure sustaining Valve (30-FLDI\FR (PR) is an automatic, float-pilot water level control and Flow control valve. The valve will open when the level reached a set opening height. The valve will regulate to limit the bigger of the downstream pressure or flow values. In case both values are lower than their set-value, the valve will open to minimize losses. The differential between opening and closing levels is adjustable.



S300 Features

- Superb performance:
 - Regulates at a stable mode, regardless of valve-size, down to near-zero flow. Thus, eliminating the need for a special low flow plug-design (such as 'V-port') or a bypass valve.
 - 'Floating', low-friction internal-trim design, guided by unique LPT® device.
- High reliability:
 - All control ports are fitted with SST sleeves for preventing corrosion-blockage.
 - Pre-shaped reinforced diaphragm – for easier assembly and improved longevity.
- Reduced periodic inspection/maintenance labor:
 - The control-trim is fitted with a self-flushing, inline control-filter.
 - Easy in-situ adjustment and maintenance.
- Versatility:
 - A standard and simple single-chamber valve design, provides smooth operation. Conversion to a double chamber is a patented option.

Standard Materials

- Body & Cover – Ductile Iron
Optional – Cast Steel, SST, N.A.B, S.Duplex
- Main Internal – SST (1.5"-6), Coated steel (8"-32")
Optional – Cast Steel, SST, N.A.B, S.Duplex
- Elastomers – EPDM
Optional – NBR, Neoprene, Viton or others
- Coating – Polyester, Epoxy / Optional – Halar and others
- Control trim – Brass, PA / Optional – SST316, Duplex

Purchase Specifications

- The valve will be hydraulic, pilot-operated globe type.
- Face-to-face length dimension meets ISO 5752 Standard.
- The stem will be guided at the top by a replaceable guide bearing and at the bottom by a stainless steel unique LPT® device.
- The valve will regulate any flow within the specified range without the need for a smaller bypass valve or throttling plug.
- All control ports will be corrosion free protected by stainless steel 316 inserts.

Design Considerations

- The valve should be suited for the maximal flow and allowed Headloss.
- For low pressure systems, consider a 3-way control pilots.
- Large pressure differentials may cause cavitation damage. Consult Dorot for solutions if such conditions are expected.

Quick Sizing

- Valve sized to be the same as line-size or one nominal-size smaller.
- Maximum recommended flow velocity for continuous operation 5.5 m/sec (18 ft. /sec).

Pressure rating

- Model 30, 30A for medium pressure (PN16 bar / 250 psi)
- Model 31, 31A for high pressure (PN25 bar / 360 psi)

Typical Installation

Typical applications include a Differential Float Valve Model 30-FLDI\FR (PR). The valve will open when the level reached a set opening height. The valve will regulate to limit the bigger of the downstream pressure or flow values.

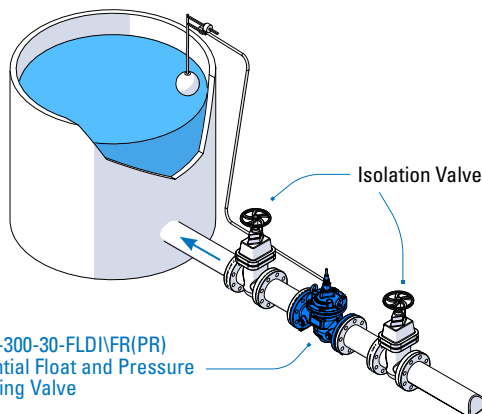

Main Control System Components*

- | | |
|-------------------------|--------------------|
| 1. Main Valve | 7. 68-410 PR Pilot |
| 2. Ball valve | 8. Pressure gauge |
| 3. Self-flushing filter | 9. 28-200 Relay |
| 4. 3W FLDI Pilot Valve | 10. Orifice |
| 5. 3W Ball valve | |
| 6. Orifice (Optional) | |

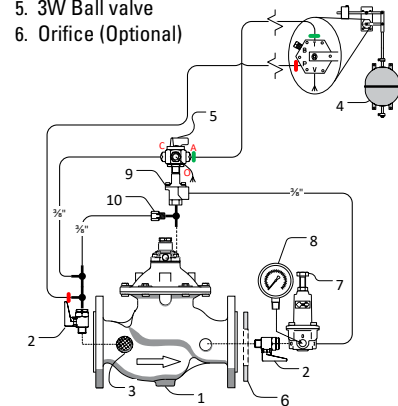

30-FLDI\SP Differential-Level Control Valve with Surge-Preventing closure

Principal of operation

The Dorot Series 300 Differential Float Control Valve ('30-FLDI\SP') is an automatic, Float actuated, Differential-Level Control Valve with Surge-Preventing closure. The valve will open when the level reached a set opening height and close on a set lower/higher level. The differential between opening and closing levels is adjustable. The closure velocity is automatically and dynamically self-adjusted to prevent surges.

*The SP device can be added to any control function.

Please consult Dorot for more details



S300 Features

- Superb performance:
 - Regulates at a stable mode, regardless of valve-size, down to near-zero flow. Thus, eliminating the need for a special low flow plug-design (such as 'V-port') or a bypass valve.
 - 'Floating', low-friction internal-trim design, guided by unique LPT® device.
- High reliability:
 - All control ports are fitted with SST sleeves for preventing corrosion-blockage.
 - Pre-shaped reinforced diaphragm – for easier assembly and improved longevity.
- Reduced periodic inspection/maintenance labor:
 - The control-trim is fitted with a self-flushing, inline control-filter.
 - Easy in-situ adjustment and maintenance.
- Versatility:
 - A standard and simple single-chamber valve design, provides smooth operation. Conversion to a double chamber is a patented option.

Standard Materials

- Body & Cover – Ductile Iron
Optional – Cast Steel, SST, N.A.B, S.Duplex
- Main Internal – SST (1.5"-6), Coated steel (8"-32")
Optional – Cast Steel, SST, N.A.B, S.Duplex
- Elastomers – EPDM
Optional – NBR, Neoprene, Viton or others
- Coating – Polyester, Epoxy / Optional – Halar and others
- Control trim – Brass, PA / Optional – SST316, Duplex

Purchase Specifications

- The valve will be hydraulic, pilot-operated globe type.
- Face-to-face length dimension meets ISO 5752 Standard.
- The stem will be guided at the top by a replaceable guide bearing and at the bottom by a stainless steel unique LPT® device.
- The valve will regulate any flow within the specified range without the need for a smaller bypass valve or throttling plug.
- All control ports will be corrosion free protected by stainless steel 316 inserts.

Design Considerations

- The valve should be suited for the maximal flow and allowed Headloss.
- Large pressure differentials may cause cavitation damage. Consult Dorot for solutions if such conditions are expected.

Quick Sizing

- Valve sized to be the same as line-size or one nominal-size smaller.
- Maximum recommended flow velocity for continuous operation 5.5 m/sec (18 ft. /sec).

Pressure rating

- Model 30, 30A for medium pressure (PN16 bar / 250 psi)
- Model 31, 31A for high pressure (PN25 bar / 360 psi)

Typical Installation

Typical applications include a Differential Float Valve Model 30-FLDI\SP. The valve will open when the level reached a set opening height and close on a set lower/higher level. The differential between opening and closing levels is adjustable. The closure speed is automatically and dynamically self-adjusted to prevent surges.

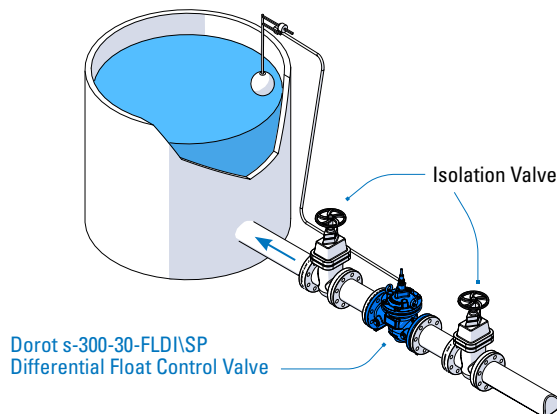

Main Control System Components*

1. Main Valve
2. Ball valve
3. Self-flushing filter
4. 3W FLDI Pilot Valve
5. 3W Ball valve
6. Orifice (Optional)
7. CXPR Pilot
8. Pressure gauge

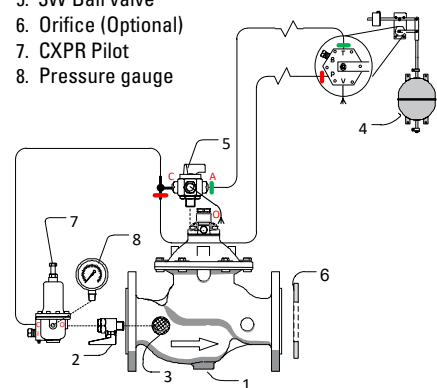

* Indicative drawing

30-AL 3W Altitude Pilot Controlled Valve

Principal of operation

The Dorot Series 300 Altitude Pilot Control Valve ('30-AL') is an automatic, pilot controlled, level control valve, activated by the pressure of the pipeline. The main valve is controlled by a highly sensitive pilot, located outside the tank. The pilot opens or closes the valve in response to the static pressure of the water. The pilot allows for differential adjustments between the maximum and minimum level.

*Optional Addition: 'FR (PR)' Flow control function.



S300 Features

- Superb performance:
 - Regulates at a stable mode, regardless of valve-size, down to near-zero flow. Thus, eliminating the need for a special low flow plug-design (such as 'V-port') or a bypass valve.
 - 'Floating', low-friction internal-trim design, guided by unique LPT® device.
- High reliability:
 - All control ports are fitted with SST sleeves for preventing corrosion-blockage.
 - Pre-shaped reinforced diaphragm – for easier assembly and improved longevity.
- Reduced periodic inspection/maintenance labor:
 - The control-trim is fitted with a self-flushing, inline control-filter.
 - Easy in-situ adjustment and maintenance.
- Versatility:
 - A standard and simple single-chamber valve design, provides smooth operation. Conversion to a double chamber is a patented option.

Standard Materials

- Body & Cover – Ductile Iron
Optional – Cast Steel, SST, N.A.B, S.Duplex
- Main Internal – SST (1.5"-6), Coated steel (8"-32")
Optional – Cast Steel, SST, N.A.B, S.Duplex
- Elastomers – EPDM
Optional – NBR, Neoprene, Viton or others
- Coating – Polyester, Epoxy / Optional – Halar and others
- Control trim – Brass, PA / Optional – SST316, Duplex

Purchase Specifications

- The valve will be hydraulic, pilot-operated globe type.
- Face-to-face length dimension meets ISO 5752 Standard.
- The stem will be guided at the top by a replaceable guide bearing and at the bottom by a stainless steel unique LPT® device.
- The valve will regulate any flow within the specified range without the need for a smaller bypass valve or throttling plug.
- All control ports will be corrosion free protected by stainless steel 316 inserts.

Design Considerations

- The valve should be suited for the maximal flow and allowed Headloss.
- Large pressure differentials may cause cavitation damage. Consult Dorot for solutions if such conditions are expected.

Quick Sizing

- Valve sized to be the same as line-size or one nominal-size smaller.
- Maximum recommended flow velocity for continuous operation 5.5 m/sec (18 ft. /sec).

Pressure rating

- Model 30, 30A for medium pressure (PN16 bar / 250 psi)
- Model 31, 31A for high pressure (PN25 bar / 360 psi)

Typical Installation

Typical applications include Altitude Pilot Control Valve Model 30-AL. Dorot Altitude Pilot Controlled Valve controlling the water volume in an elevated tank. (Integrated features such as Flow control, cavitation and water hammer protections are available).

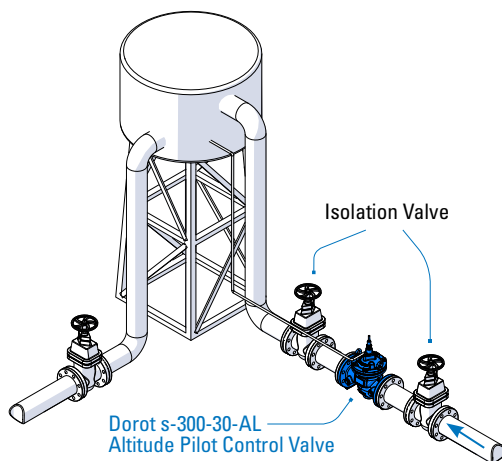

Main Control System Components*

1. Main Valve
2. Ball valve
3. Self-flushing filter
4. 3W AL Pilot Valve
5. 3W Ball valve
6. 3w Relay (Sizes 8" and above)
7. Orifice (Optional)

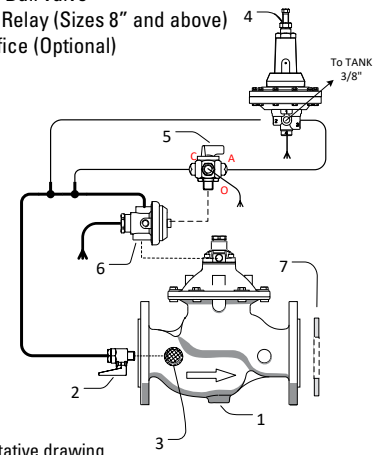

* Indicative drawing

CXAL 2W Altitude Pilot Controlled Valve

Principal of operation

The Dorot Series 300 Altitude 2w Pilot Control Valve ('30-CXAL) is an automatic, pilot controlled, level control valve, activated by the pressure of the pipeline. The main valve is controlled by a highly sensitive pilot, located outside the tank. The pilot opens or closes the valve in response to the static pressure of the water.



S300 Features

- Superb performance:
 - Regulates at a stable mode, regardless of valve-size, down to near-zero flow. Thus, eliminating the need for a special low flow plug-design (such as 'V-port') or a bypass valve.
 - 'Floating', low-friction internal-trim design, guided by unique LPT® device.
- High reliability:
 - All control ports are fitted with SST sleeves for preventing corrosion-blockage.
 - Pre-shaped reinforced diaphragm – for easier assembly and improved longevity.
- Reduced periodic inspection/maintenance labor:
 - The control-trim is fitted with a self-flushing, inline control-filter.
 - Easy in-situ adjustment and maintenance.
- Versatility:
 - A standard and simple single-chamber valve design, provides smooth operation. Conversion to a double chamber is a patented option.

Standard Materials

- Body & Cover – Ductile Iron
Optional – Cast Steel, SST, N.A.B, S.Duplex
- Main Internal – SST (1.5"-6), Coated steel (8"-32")
Optional – Cast Steel, SST, N.A.B, S.Duplex
- Elastomers – EPDM
Optional – NBR, Neoprene, Viton or others
- Coating – Polyester, Epoxy / Optional – Halar and others
- Control trim – Brass, PA / Optional – SST316, Duplex

Purchase Specifications

- The valve will be hydraulic, pilot-operated globe type.
- Face-to-face length dimension meets ISO 5752 Standard.
- The stem will be guided at the top by a replaceable guide bearing and at the bottom by a stainless steel unique LPT® device.
- The valve will regulate any flow within the specified range without the need for a smaller bypass valve or throttling plug.
- All control ports will be corrosion free protected by stainless steel 316 inserts.

Design Considerations

- The valve should be suited for the maximal flow and allowed Headloss.
- Large pressure differentials may cause cavitation damage. Consult Dorot for solutions if such conditions are expected.

Quick Sizing

- Valve sized to be the same as line-size or one nominal-size smaller.
- Maximum recommended flow velocity for continuous operation 5.5 m/sec (18 ft. /sec).

Pressure rating

- Model 30, 30A for medium pressure (PN16 bar / 250 psi)
- Model 31, 31A for high pressure (PN25 bar / 360 psi)

Typical Installation

Typical applications include Altitude Pilot Control Valve Model 30-CXAL. Dorot Altitude Pilot Controlled Valve controlling the water volume in an elevated tank. (Integrated features such as Flow control, cavitation and water hammer protections are available).

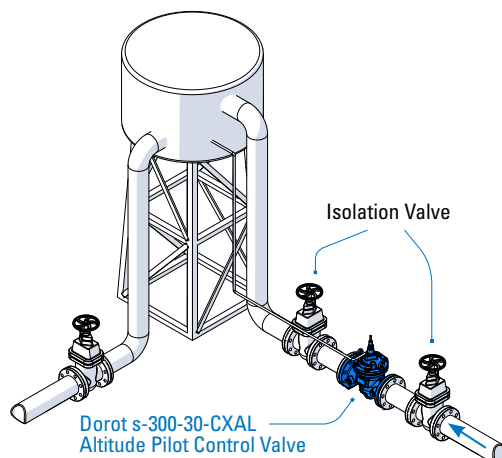

Main Control System Components*

1. Main Valve
2. Ball valve
3. Self-flushing filter
4. 2W CXAL Pilot Valve
5. Orifice (Optional)

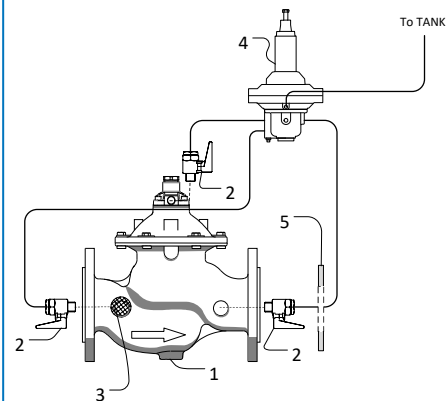

* Indicative drawing

30-BC Pump Control Valve

Principal of operation

The Dorot Series 300 Pump Control Valve ('30-BC') is an automatic controlled valve, activated by the pressure of the pipeline. The valve will minimize pump starting and stopping surges by slowly opening at pump startup and slowly closing prior to pump shutdown. The valve will close instantly on power failure.



S300 Features

- Superb performance:
 - Regulates at a stable mode, regardless of valve-size, down to near-zero flow. Thus, eliminating the need for a special low flow plug-design (such as 'V-port') or a bypass valve.
 - 'Floating', low-friction internal-trim design, guided by unique LPT® device.
- High reliability:
 - All control ports are fitted with SST sleeves for preventing corrosion-blockage.
 - Pre-shaped reinforced diaphragm – for easier assembly and improved longevity.
- Reduced periodic inspection/maintenance labor:
 - The control-trim is fitted with a self-flushing, inline control-filter.
 - Easy in-situ adjustment and maintenance.
- Versatility:
 - A standard and simple single-chamber valve design, provides smooth operation. Conversion to a double chamber is a patented option.

Standard Materials

- Body & Cover – Ductile Iron
Optional – Cast Steel, SST, N.A.B, S.Duplex
- Main Internal – SST (1.5" -6), Coated steel (8" -32")
Optional – Cast Steel, SST, N.A.B, S.Duplex
- Elastomers – EPDM
Optional – NBR, Neoprene, Viton or others
- Coating – Polyester, Epoxy / Optional – Halar and others
- Control trim – Brass, PA / Optional – SST316, Duplex

Purchase Specifications

- The valve will be hydraulic, pilot-operated globe type.
- Face-to-face length dimension meets ISO 5752 Standard.
- The stem will be guided at the top by a replaceable guide bearing and at the bottom by a stainless steel unique LPT® device.
- The valve will regulate any flow within the specified range without the need for a smaller bypass valve or throttling plug.
- All control ports will be corrosion free protected by stainless steel 316 inserts.

Design Considerations

- The valve should be suited for the maximal flow and allowed Headloss.
- Large pressure differentials may cause cavitation damage. Consult Dorot for solutions if such conditions are expected.

Quick Sizing

- Valve sized to be the same as line-size or one nominal-size smaller.
- Maximum recommended flow velocity for continuous operation 5.5 m/sec (18 ft. /sec).

Pressure rating

- Model 30, 30A for medium pressure (PN16 bar / 250 psi)
- Model 31, 31A for high pressure (PN25 bar / 360 psi)

Typical Installation

Typical applications include a Pump Control Valve Model 30-BC. The valve is assembled downstream of a pump and will open and close slowly when the solenoid is energized/de-energized respectively.

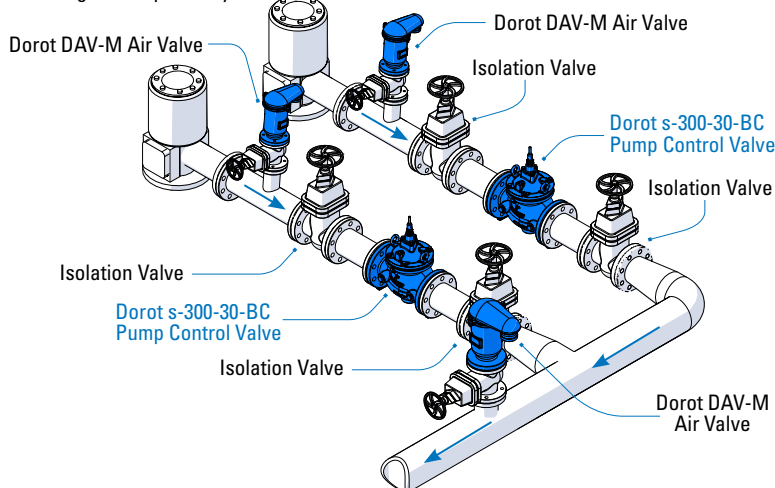

Main Control System Components*

1. 3/2 hyd. relay-valve model 66-210
2. 3/2, N.C Solenoid valve
3. 3/2 hyd. relay-valve model 28-300
4. Isolation ball-valve
5. Limit switch assembly
6. 'Y' pattern control-filter
7. Check valve
8. Needle Valve

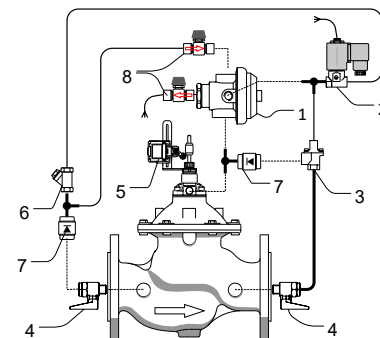

* Indicative drawing

30-BC\PS Pump Control and Pressure Sustaining Valve

Principal of operation

The Dorot Series 300 Pump Control and Pressure Sustaining Valve ('30-BC\PS') is an automatic controlled valve, activated by the pressure of the pipeline. The valve will minimize pump starting and stopping surges by slowly opening at pump startup and slowly closing prior to pump shutdown. The valve will maintain pre-set upstream pressure, limiting flow velocity at line filling stages.



S300 Features

- Superb performance:
 - Regulates at a stable mode, regardless of valve-size, down to near-zero flow. Thus, eliminating the need for a special low flow plug-design (such as 'V-port') or a bypass valve.
 - 'Floating', low-friction internal-trim design, guided by unique LPT® device.
- High reliability:
 - All control ports are fitted with SST sleeves for preventing corrosion-blockage.
 - Pre-shaped reinforced diaphragm – for easier assembly and improved longevity.
- Reduced periodic inspection/maintenance labor:
 - The control-trim is fitted with a self-flushing, inline control-filter.
 - Easy in-situ adjustment and maintenance.
- Versatility:
 - A standard and simple single-chamber valve design, provides smooth operation. Conversion to a double chamber is a patented option.

Standard Materials

- Body & Cover – Ductile Iron
Optional – Cast Steel, SST, N.A.B, S.Duplex
- Main Internal – SST (1.5"-6), Coated steel (8"-32")
Optional – Cast Steel, SST, N.A.B, S.Duplex
- Elastomers – EPDM
Optional – NBR, Neoprene, Viton or others
- Coating – Polyester, Epoxy / Optional – Halar and others
- Control trim – Brass, PA / Optional – SST316, Duplex

Purchase Specifications

- The valve will be hydraulic, pilot-operated globe type.
- Face-to-face length dimension meets ISO 5752 Standard.
- The stem will be guided at the top by a replaceable guide bearing and at the bottom by a stainless steel unique LPT® device.
- The valve will regulate any flow within the specified range without the need for a smaller bypass valve or throttling plug.
- All control ports will be corrosion free protected by stainless steel 316 inserts.

Design Considerations

- The valve should be suited for the maximal flow and allowed Headloss.
- Large pressure differentials may cause cavitation damage. Consult Dorot for solutions if such conditions are expected.

Quick Sizing

- Valve sized to be the same as line-size or one nominal-size smaller.
- Maximum recommended flow velocity for continuous operation 5.5 m/sec (18 ft. /sec).

Pressure rating

- Model 30, 30A for medium pressure (PN16 bar / 250 psi)
- Model 31, 31A for high pressure (PN25 bar / 360 psi)

Typical Installation

The Dorot Series 300 Pump Control and Pressure Sustaining Valve ('30-BC\PS') will minimize pump starting and stopping surges by slowly opening at pump startup and slowly closing prior to pump shutdown.

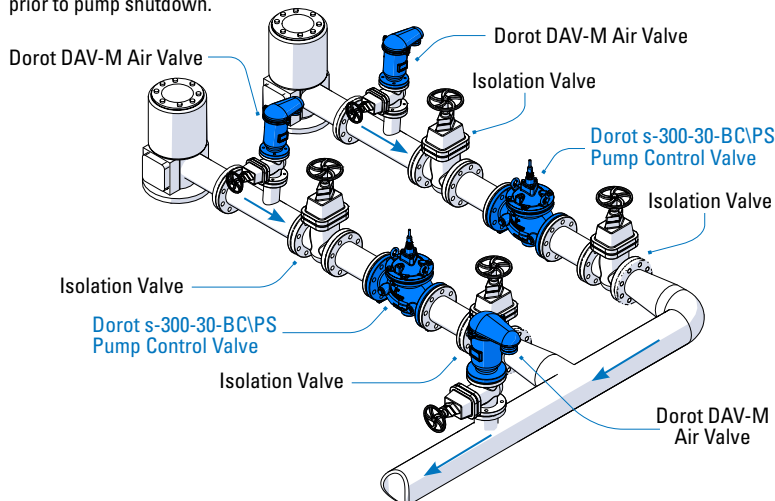

Main Control System Components*

1. Pilot valve model 31-10S
2. 3/2, N.C&N.C Solenoid valves
3. 3/2 hyd. relay-valve model 28-200
4. Isolation ball-valve
5. Limit switch assembly
6. Self flushing control-filter
7. Check valve
8. Needle Valve
9. Pressure gauge

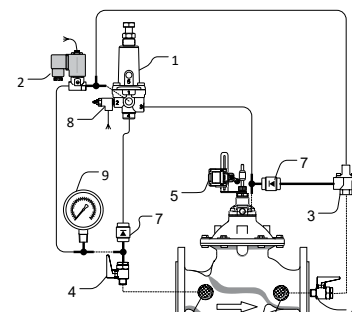

* Indicative drawing

30-NS Two-Stages, Cushioned Closure Check Valve

Principal of operation

The Dorot Series 300 Two Stages Check Valve ('30-NS'), activated by the pressure of the pipeline, The valve eliminate pressure slam of check valves, frequently found in roof-tank filling pumps of high-rise buildings. It opens on pump start, and closes at controlled pace when the pump stops.



S300 Features

- Superb performance:
 - Regulates at a stable mode, regardless of valve-size, down to near-zero flow. Thus, eliminating the need for a special low flow plug-design (such as 'V-port') or a bypass valve.
 - 'Floating', low-friction internal-trim design, guided by unique LPT® device.
- High reliability:
 - All control ports are fitted with SST sleeves for preventing corrosion-blockage.
 - Pre-shaped reinforced diaphragm – for easier assembly and improved longevity.
- Reduced periodic inspection/maintenance labor:
 - The control-trim is fitted with a self-flushing, inline control-filter.
 - Easy in-situ adjustment and maintenance.
- Versatility:
 - A standard and simple single-chamber valve design, provides smooth operation. Conversion to a double chamber is a patented option.

Standard Materials

- Body & Cover – Ductile Iron
Optional – Cast Steel, SST, N.A.B, S.Duplex
- Main Internal – SST (1.5"-6), Coated steel (8"-32")
Optional – Cast Steel, SST, N.A.B, S.Duplex
- Elastomers – EPDM
Optional – NBR, Neoprene, Viton or others
- Coating – Polyester, Epoxy / Optional – Halar and others
- Control trim – Brass, PA / Optional – SST316, Duplex

Purchase Specifications

- The valve will be hydraulic, pilot-operated globe type.
- Face-to-face length dimension meets ISO 5752 Standard.
- The stem will be guided at the top by a replaceable guide bearing and at the bottom by a stainless steel unique LPT® device.
- The valve will regulate any flow within the specified range without the need for a smaller bypass valve or throttling plug.
- All control ports will be corrosion free protected by stainless steel 316 inserts.

Design Considerations

- The valve should be suited for the maximal flow and allowed Headloss.
- Large pressure differentials may cause cavitation damage. Consult Dorot for solutions if such conditions are expected.

Quick Sizing

- Valve sized to be the same as line-size or one nominal-size smaller.
- Maximum recommended flow velocity for continuous operation 5.5 m/sec (18 ft. /sec).

Pressure rating

- Model 30, 30A for medium pressure (PN16 bar / 250 psi)
- Model 31, 31A for high pressure (PN25 bar / 360 psi)

Typical Installation

Typical applications Includes a Two Stages check valve Model 30-NS. The valve eliminate pressure slam of check valves, frequently found in roof-tank filling pumps of high-rise buildings. It opens on pump start, and closes at controlled pace when the pump stops.

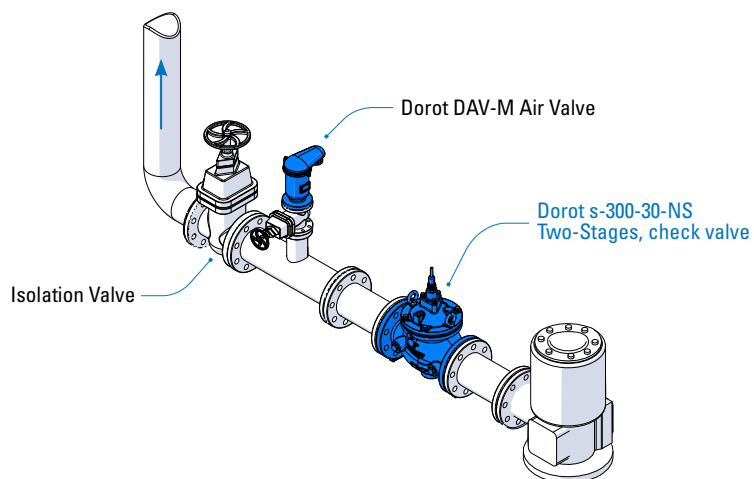

Main Control System Components*

1. Main Valve
2. Ball valve
3. Line filter
4. NS device

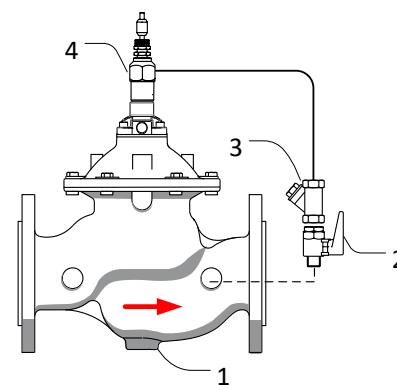

* Indicative drawing

30-CV Hydraulic Non-Return Valve

Principal of operation

The Dorot Series 300 Hydraulic None-Return Valve ('30-CV'), activated by the pressure of the pipeline, The valve will open when the upstream pressure is higher than the downstream pressure and close drip tight in case the upstream pressure is equal or lower than the downstream pressure. The opening and closing speed is slow and controllable, so to prevent the risk for water-hammer / surge.



S300 Features

- Superb performance:
 - Regulates at a stable mode, regardless of valve-size, down to near-zero flow. Thus, eliminating the need for a special low flow plug-design (such as 'V-port') or a bypass valve.
 - 'Floating', low-friction internal-trim design, guided by unique LPT® device.
- High reliability:
 - All control ports are fitted with SST sleeves for preventing corrosion-blockage.
 - Pre-shaped reinforced diaphragm – for easier assembly and improved longevity.
- Reduced periodic inspection/maintenance labor:
 - The control-trim is fitted with a self-flushing, inline control-filter.
 - Easy in-situ adjustment and maintenance.
- Versatility:
 - A standard and simple single-chamber valve design, provides smooth operation. Conversion to a double chamber is a patented option.

Standard Materials

- Body & Cover – Ductile Iron
Optional – Cast Steel, SST, N.A.B, S.Duplex
- Main Internal – SST (1.5"-6), Coated steel (8"-32")
Optional – Cast Steel, SST, N.A.B, S.Duplex
- Elastomers – EPDM
Optional – NBR, Neoprene, Viton or others
- Coating – Polyester, Epoxy / Optional – Halar and others
- Control trim – Brass, PA / Optional – SST316, Duplex

Purchase Specifications

- The valve will be hydraulic, pilot-operated globe type.
- Face-to-face length dimension meets ISO 5752 Standard.
- The stem will be guided at the top by a replaceable guide bearing and at the bottom by a stainless steel unique LPT® device.
- The valve will regulate any flow within the specified range without the need for a smaller bypass valve or throttling plug.
- All control ports will be corrosion free protected by stainless steel 316 inserts.

Design Considerations

- The valve should be suited for the maximal flow and allowed Headloss.
- Large pressure differentials may cause cavitation damage. Consult Dorot for solutions if such conditions are expected.

Quick Sizing

- Valve sized to be the same as line-size or one nominal-size smaller.
- Maximum recommended flow velocity for continuous operation 5.5 m/sec (18 ft. /sec).

Pressure rating

- Model 30, 30A for medium pressure (PN16 bar / 250 psi)
- Model 31, 31A for high pressure (PN25 bar / 360 psi)

Typical Installation

Typical applications Includes a Two Stages check valve Model 30-CV. The valve will open when the upstream pressure is higher than the Downstream pressure and close drip tight in case the upstream pressure is equal or lower than the downstream pressure.

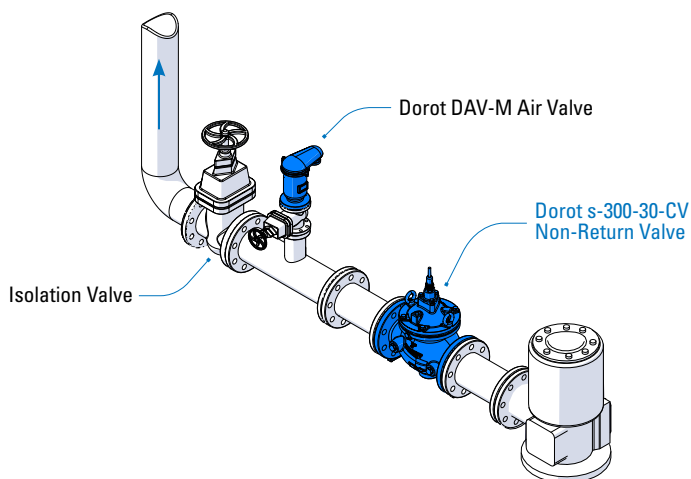

Main Control System Components*

1. Main Valve
2. Ball valve
3. Needle valve

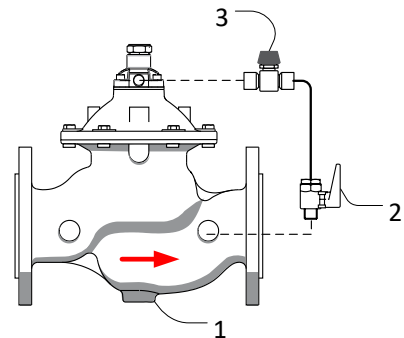

* Indicative drawing

30-DW Deep Well (Borehole) Pump Control Valve

Principal of operation

The Dorot Series 300 Deep Well Pump Control Valve ('30-DW') is an automatic controlled valve, activated by the pressure of the pipeline. When the pump starts, the valve slowly closes, gradually increasing network pressure. Before pump shut-off, the valve slowly opens, gradually reducing network pressure.



S300 Features

- Superb performance:
 - Regulates at a stable mode, regardless of valve-size, down to near-zero flow. Thus, eliminating the need for a special low flow plug-design (such as 'V-port') or a bypass valve.
 - 'Floating', low-friction internal-trim design, guided by unique LPT® device.
- High reliability:
 - All control ports are fitted with SST sleeves for preventing corrosion-blockage.
 - Pre-shaped reinforced diaphragm – for easier assembly and improved longevity.
- Reduced periodic inspection/maintenance labor:
 - The control-trim is fitted with a self-flushing, inline control-filter.
 - Easy in-situ adjustment and maintenance.
- Versatility:
 - A standard and simple single-chamber valve design, provides smooth operation. Conversion to a double chamber is a patented option.

Standard Materials

- Body & Cover – Ductile Iron
Optional – Cast Steel, SST, N.A.B, S.Duplex
- Main Internal – SST (1.5"-6), Coated steel (8"-32")
Optional – Cast Steel, SST, N.A.B, S.Duplex
- Elastomers – EPDM
Optional – NBR, Neoprene, Viton or others
- Coating – Polyester, Epoxy / Optional – Halar and others
- Control trim – Brass, PA / Optional – SST316, Duplex

Purchase Specifications

- The valve will be hydraulic, pilot-operated globe type.
- Face-to-face length dimension meets ISO 5752 Standard.
- The stem will be guided at the top by a replaceable guide bearing and at the bottom by a stainless steel unique LPT® device.
- The valve will regulate any flow within the specified range without the need for a smaller bypass valve or throttling plug.
- All control ports will be corrosion free protected by stainless steel 316 inserts.

Design Considerations

- The valve should be suited for the maximal flow and allowed Headloss.
- Large pressure differentials may cause cavitation damage. Consult Dorot for solutions if such conditions are expected.

Quick Sizing

- The valve should be sized to match the well flow at 5 mwc/8 psi in the valve site (pump head water table depth):
 $D[\text{mm}] \geq 170 \times \sqrt{\text{Flow} [\text{m}^3/\text{hr}]}$
 $D[\text{inch}] \geq 0.55 \times \sqrt{\text{Flow} [\text{gpm}]}$

Pressure rating

- Model 30, 30A for medium pressure (PN16 bar / 250 psi)
- Model 31, 31A for high pressure (PN25 bar / 360 psi)

Typical Installation

Typical applications include a Pump Control Valve Model 30-DW. The valve eliminates surges caused by the start-up and shut-off of vertical or submersible pumps. It is a relief valve, assembled on a T-junction of the main pipeline

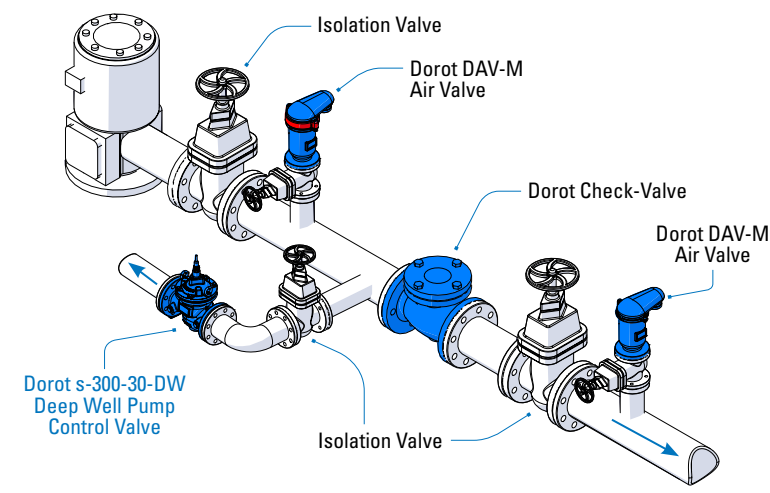

Main Control System Components*

1. S300 valve
2. 3/2, N.O& N.C Solenoid valves
3. Self-Flushing, inline control-filter
4. Isolation ball-valve
5. Limit switch assembly
6. Check valve
7. Needle valve

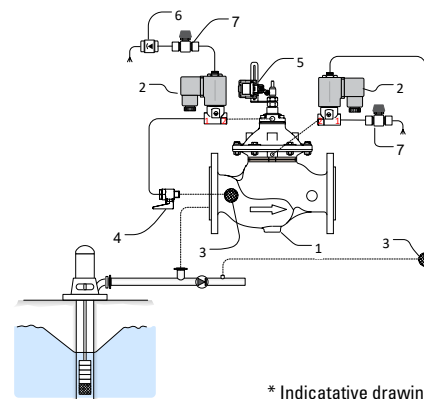

* Indicative drawing

30-RE Surge Anticipating Valve

Principal of operation

The Dorot Series 300 Surge Anticipating Valve ('30-RE') is an automatic controlled valve, activated by the pressure of the pipeline. The valve protects the pumping system from water hammer, caused by sudden pump shut-off (case of power failure, for example). The valve is assembled on a T-junction of the main pipeline, instantly opens when the pump stops, relieving the returning high pressure wave. The valve slowly closes once the pressure returns to the static level. The valve also functions as a pressure relief valve.



S300 Features

- Superb performance:
 - Regulates at a stable mode, regardless of valve-size, down to near-zero flow. Thus, eliminating the need for a special low flow plug-design (such as 'V-port') or a bypass valve.
 - 'Floating', low-friction internal-trim design, guided by unique LPT® device.
- High reliability:
 - All control ports are fitted with SST sleeves for preventing corrosion-blockage.
 - Pre-shaped reinforced diaphragm – for easier assembly and improved longevity.
- Reduced periodic inspection/maintenance labor:
 - The control-trim is fitted with a self-flushing, inline control-filter.
 - Easy in-situ adjustment and maintenance.
- Versatility:
 - A standard and simple single-chamber valve design, provides smooth operation. Conversion to a double chamber is a patented option.

Standard Materials

- Body & Cover – Ductile Iron
Optional – Cast Steel, SST, N.A.B, S.Duplex
- Main Internal – SST (1.5"-6), Coated steel (8"-32")
Optional – Cast Steel, SST, N.A.B, S.Duplex
- Elastomers – EPDM
Optional – NBR, Neoprene, Viton or others
- Coating – Polyester, Epoxy / Optional – Halar and others
- Control trim – Brass, PA / Optional – SST316, Duplex

Purchase Specifications

- The valve will be hydraulic, pilot-operated globe type.
- Face-to-face length dimension meets ISO 5752 Standard.
- The stem will be guided at the top by a replaceable guide bearing and at the bottom by a stainless steel unique LPT® device.
- The valve will regulate any flow within the specified range without the need for a smaller bypass valve or throttling plug.
- All control ports will be corrosion free protected by stainless steel 316 inserts.

Design Considerations

- The valve should be suited for the maximal flow.
- Install a manual separation/throttling valve, upstream of the valve position.
- The valve sensor tube must be connected to the main line.

Quick Sizing

- The valve should be sized to match the 80% of the normal flow at static head in the valve site:
 $D[\text{mm}] \geq \sqrt{(250 \times \text{Flow}[\text{m}^3/\text{hr}] / \sqrt{\text{Pressure}[\text{mwc}]})}$
 $D[\text{inch}] \geq \sqrt{(0.109 \times \text{Flow}[\text{gpm}] / \sqrt{\text{Pressure}[\text{psi}]})}$

Pressure rating

- Model 30, 30A for medium pressure (PN16 bar / 250 psi)
- Model 31, 31A for high pressure (PN25 bar / 360 psi)

Typical Installation

Typical applications include Pressure Sustaining Valve Model 30-RE. The Dorot Surge Anticipating Valve prevents water-hammer surges caused by an un-expected pump shut-off.

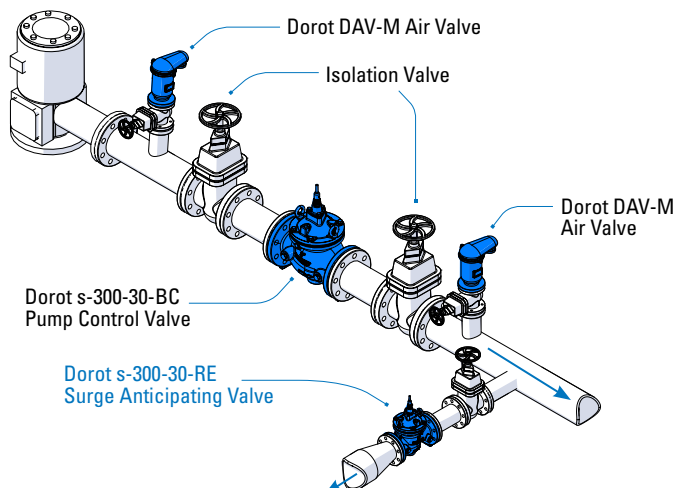

Main Control System Components*

1. Main Valve
2. Ball valve
3. Filter
4. 2W Pilot Valve
5. 3W Pilot Valve
6. Fast Acting Relay
7. Pressure Gauge
8. Needle Valve
9. Check Valve

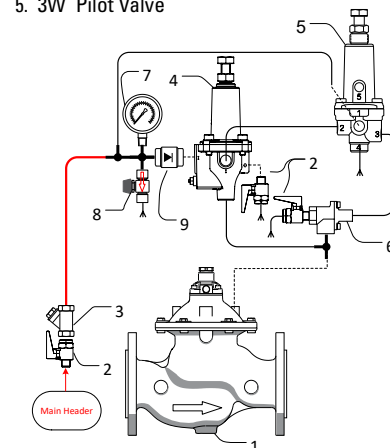

* Indicative drawing

30-REEL Surge Anticipating Valve

Principal of operation

The Dorot Series 300 Surge Anticipating Valve ('30-REEL') is an automatic, solenoid controlled surge anticipating valve, activated by the pressure of the pipeline. The valve will maintain a drip tight closed position under normal operating conditions and will open fully when the solenoid is energized; the valve closes at a slow pace preventing secondary surges when the solenoid de-energized. The valve will also open to relief access pressure in the line.



S300 Features

- Superb performance:
 - Regulates at a stable mode, regardless of valve-size, down to near-zero flow. Thus, eliminating the need for a special low flow plug-design (such as 'V-port') or a bypass valve.
 - 'Floating', low-friction internal-trim design, guided by unique LPT® device.
- High reliability:
 - All control ports are fitted with SST sleeves for preventing corrosion-blockage.
 - Pre-shaped reinforced diaphragm – for easier assembly and improved longevity.
- Reduced periodic inspection/maintenance labor:
 - The control-trim is fitted with a self-flushing, inline control-filter.
 - Easy in-situ adjustment and maintenance.
- Versatility:
 - A standard and simple single-chamber valve design, provides smooth operation. Conversion to a double chamber is a patented option.

Standard Materials

- Body & Cover – Ductile Iron
Optional – Cast Steel, SST, N.A.B, S.Duplex
- Main Internal – SST (1.5"-6), Coated steel (8"-32")
Optional – Cast Steel, SST, N.A.B, S.Duplex
- Elastomers – EPDM
Optional – NBR, Neoprene, Viton or others
- Coating – Polyester, Epoxy / Optional – Halar and others
- Control trim – Brass, PA / Optional – SST316, Duplex

Purchase Specifications

- The valve will be hydraulic, pilot-operated globe type.
- Face-to-face length dimension meets ISO 5752 Standard.
- The stem will be guided at the top by a replaceable guide bearing and at the bottom by a stainless steel unique LPT® device.
- The valve will regulate any flow within the specified range without the need for a smaller bypass valve or throttling plug.
- All control ports will be corrosion free protected by stainless steel 316 inserts.

Design Considerations

- The valve should be suited for the maximal flow.
- Install a manual separation/throttling valve, upstream of the valve position.
- The valve sensor tube must be connected to the main line.

Quick Sizing

- The valve should be sized to match the 80% of the normal flow at static head in the valve site:

$$D[\text{mm}] \geq \sqrt{(250 \times \text{Flow}[\text{m}^3/\text{hr}] / \sqrt{\text{Pressure}[\text{mwc}]})}$$

$$D[\text{inch}] \geq \sqrt{(0.109 \times \text{Flow}[\text{gpm}] / \sqrt{\text{Pressure}[\text{psi}]})}$$

Pressure rating

- Model 30, 30A for medium pressure (PN16 bar / 250 psi)
- Model 31, 31A for high pressure (PN25 bar / 360 psi)

Typical Installation

Typical applications include Pressure Sustaining Valve Model 30-REEL. The Dorot Surge Anticipating Valve prevents water-hammer surges caused by an un-expected pump shut-off.

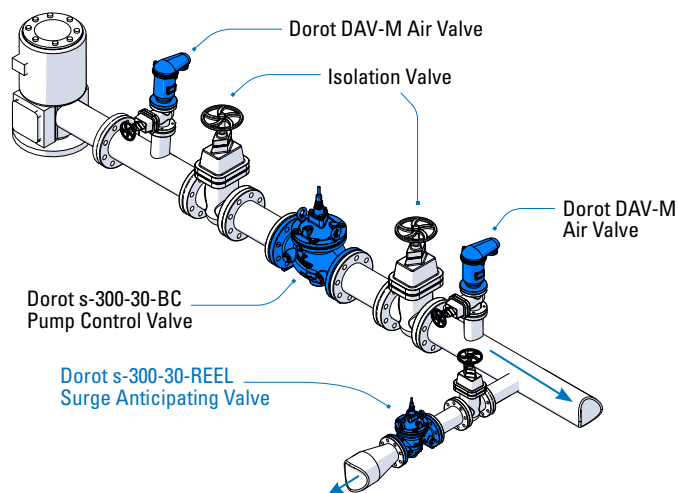

Main Control System Components*

1. Main Valve
2. Ball valve
3. Filter
4. 2W Pilot Valve
5. Solenoid Valve
6. Fast Acting Relay
7. Pressure Gauge

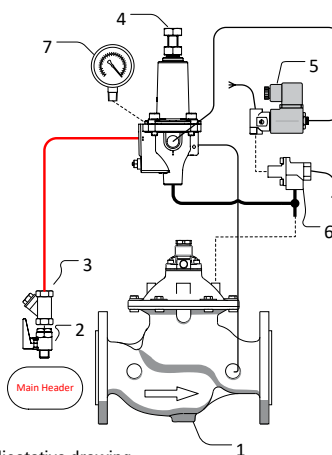

* Indicative drawing

30-QR Quick Pressure-Relief Valve

Principal of operation

The Dorot Series 300 Quick Relief Valve ('30-QR') activates by the pressure of the pipeline. The valve opens instantly when the pressure in the pipeline exceeds the safe level, thus relieving excessive pressure from the network. When the pressure returns to normal, the valve closes slowly, at an adjustable pace.



S300 Features

- Superb performance:
 - Regulates at a stable mode, regardless of valve-size, down to near-zero flow. Thus, eliminating the need for a special low flow plug-design (such as 'V-port') or a bypass valve.
 - 'Floating', low-friction internal-trim design, guided by unique LPT® device.
- High reliability:
 - All control ports are fitted with SST sleeves for preventing corrosion-blockage.
 - Pre-shaped reinforced diaphragm – for easier assembly and improved longevity.
- Reduced periodic inspection/maintenance labor:
 - The control-trim is fitted with a self-flushing, inline control-filter.
 - Easy in-situ adjustment and maintenance.
- Versatility:
 - A standard and simple single-chamber valve design, provides smooth operation. Conversion to a double chamber is a patented option.

Standard Materials

- Body & Cover – Ductile Iron
Optional – Cast Steel, SST, N.A.B, S.Duplex
- Main Internal – SST (1.5"-6), Coated steel (8"-32")
Optional – Cast Steel, SST, N.A.B, S.Duplex
- Elastomers – EPDM
Optional – NBR, Neoprene, Viton or others
- Coating – Polyester, Epoxy / Optional – Halar and others
- Control trim – Brass, PA / Optional – SST316, Duplex

Purchase Specifications

- The valve will be hydraulic, pilot-operated globe type.
- Face-to-face length dimension meets ISO 5752 Standard.
- The stem will be guided at the top by a replaceable guide bearing and at the bottom by a stainless steel unique LPT® device.
- The valve will regulate any flow within the specified range without the need for a smaller bypass valve or throttling plug.
- All control ports will be corrosion free protected by stainless steel 316 inserts.

Design Considerations

- The valve should be suited for the maximal flow and allowed Headloss.
- Large pressure differentials may cause cavitation damage. Consult Dorot for solutions if such conditions are expected.

Quick Sizing

- The valve should be sized to match the expected relief flow at the set opening pressure:

$$D[\text{mm}] \geq \sqrt{(250 \times \text{Flow}[\text{m}^3/\text{hr.}] / \sqrt{\text{Pressure}[\text{mwc}]})}$$

$$D[\text{inch}] \geq \sqrt{(0.109 \times \text{Flow}[\text{gpm}] / \sqrt{\text{Pressure}[\text{psi}]})}$$

Pressure rating

- Model 30, 30A for medium pressure (PN16 bar / 250 psi)
- Model 31, 31A for high pressure (PN25 bar / 360 psi)

Typical Installation

Typical applications include Pressure Sustaining Valve Model 30-QR. The Dorot Quick Pressure-relief Valve protects a system against pressure surges caused by pump start-up or valves closure.

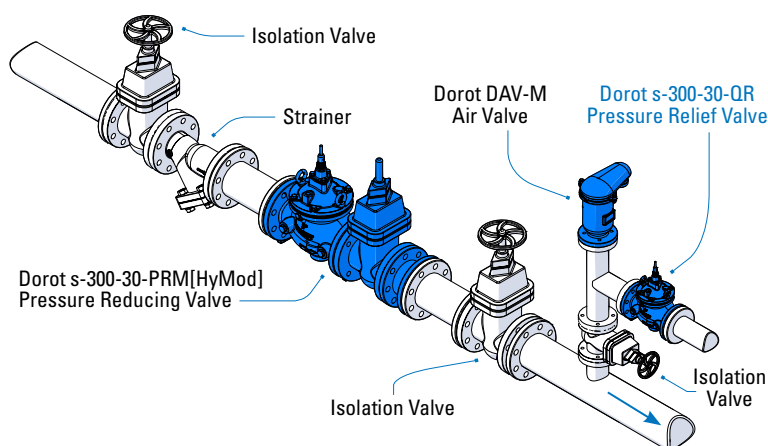

Main Control System Components*

1. Main Valve
2. Ball valve
3. Self-flushing filter
4. 2W PS Pilot Valve
5. Pressure Gauge

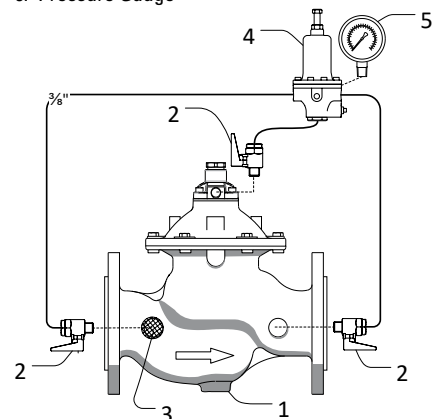

* Indicative drawing

30-FE Excessive Flow Shut-off Valve

Principal of operation

The Dorot Series 300 Excessive Flow Shut-off Valve ('30-FE') activates by the pressure of the pipeline. The valve closes drip tight when the flow rate exceeds the normal value (due to pipe rupture). The valve will manually re-set open after fixing the break.



S300 Features

- Superb performance:
 - Regulates at a stable mode, regardless of valve-size, down to near-zero flow. Thus, eliminating the need for a special low flow plug-design (such as 'V-port') or a bypass valve.
 - 'Floating', low-friction internal-trim design, guided by unique LPT® device.
- High reliability:
 - All control ports are fitted with SST sleeves for preventing corrosion-blockage.
 - Pre-shaped reinforced diaphragm – for easier assembly and improved longevity.
- Reduced periodic inspection/maintenance labor:
 - The control-trim is fitted with a self-flushing, inline control-filter.
 - Easy in-situ adjustment and maintenance.
- Versatility:
 - A standard and simple single-chamber valve design, provides smooth operation. Conversion to a double chamber is a patented option.

Standard Materials

- Body & Cover – Ductile Iron
Optional – Cast Steel, SST, N.A.B, S.Duplex
- Main Internal – SST (1.5"-6), Coated steel (8"-32")
Optional – Cast Steel, SST, N.A.B, S.Duplex
- Elastomers – EPDM
Optional – NBR, Neoprene, Viton or others
- Coating – Polyester, Epoxy / Optional – Halar and others
- Control trim – Brass, PA / Optional – SST316, Duplex

Purchase Specifications

- The valve will be hydraulic, pilot-operated globe type.
- Face-to-face length dimension meets ISO 5752 Standard.
- The stem will be guided at the top by a replaceable guide bearing and at the bottom by a stainless steel unique LPT® device.
- The valve will regulate any flow within the specified range without the need for a smaller bypass valve or throttling plug.
- All control ports will be corrosion free protected by stainless steel 316 inserts.

Design Considerations

- The valve should be suited for the maximal flow and allowed Headloss.
- For low pressure systems, consider a 3-way control pilots.

Quick Sizing

- Valve sized to be the same as line-size or one nominal-size smaller.
- Maximum recommended flow velocity for continuous operation 5.5 m/sec (18 ft. /sec).

Pressure rating

- Model 30, 30A for medium pressure (PN16 bar / 250 psi)
- Model 31, 31A for high pressure (PN25 bar / 360 psi)

Typical Installation

Typical applications include excessive flow shutoff valve Model 30-FE. Dorot excessive flow shutoff valve installed to prevent flood damages caused by pipe rupture.

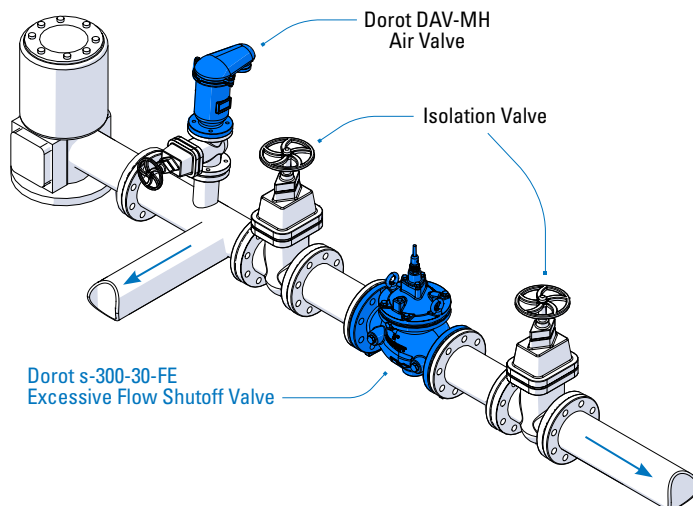

Main Control System Components*

1. Main Valve
2. Ball valve
3. Self-flushing filter
4. CXSD Pilot Valve
5. Orifice plate

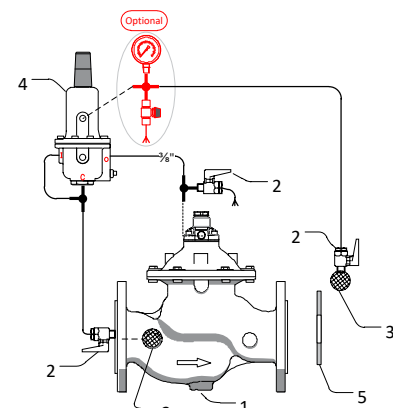

* Indicative drawing

The Dorot 300 series valves are UL-listed to be used in Fire Protection Systems at various ranges of applications.

Deluge Valves

The Dorot UL Deluge Valves are suitable for systems that include Electric, Hydraulic or Pneumatic detections. The Dorot 300 series Deluge Valves are activated by each signal or by combinations thereof. All applications are equipped with a manual emergency actuation valve and approved for use in Fire Protection Systems as Automatic Reset or Manual Reset Valves.



DE/EL

Monitor Valves

The Dorot 300 Series Monitor Valves are designed to open immediately as a response to Electric, Hydraulic, Pneumatic or manual activation. The valves use the line pressure to develop maximum power and do not need any external source of power.

The Dorot 300 Series Monitor Valves are designed to be activated locally or remotely.

Pressure Reducing Valves

The Dorot 300 Series UL Pressure Reducing Valves are hydraulically self-operating Diaphragm Valves that reduce High upstream pressure to Lower downstream pressure regardless of the upstream pressure fluctuation or unstable flow demand.

The Dorot 300 Series UL Pressure Reducing Valves are designed to maintain constant downstream pressure at all flow conditions.



PR/UL

Pressure Relief Valves

The Dorot 300 Series UL Pressure Relief Valves are designed to maintain constant pressure in the fire Protection System and prevent over pressure by relieving excess pressure back to the reservoir or vent to the atmosphere.



PS/UL

Additional information about the Dorot 300 series Fire Protection applications can be found in the Dorot Fire Protection catalogue.



Innovation

Innovation

Expertise

Expertise

Reliability

Reliability



Hundreds of companies in the industrial, civil engineering, municipal and agricultural sectors around the world have chosen DOROT's innovative and field-proven technologies. Since its establishment in 1946, DOROT leads the valves market with continued innovation, uncompromising excellence and firm commitment to its customers, consulting and supporting them through all stages of a project and overcoming challenges in R&D, design, implementation, and maintenance.



www.dorot.com